

Panasonic[®]

Operating Instructions High Definition Plasma Display

Model No. **TH-42PF11EK**
TH-50PF11EK
TH-58PF11EK
TH-65PF11EK



The illustration shown is an image.

Please read these instructions before operating your set
and retain them for future reference.

English



TQB0E0703U-2

Dear Panasonic Customer

Welcome to the Panasonic family of customers. We hope that you will have many years of enjoyment from your new Plasma Display.

To obtain maximum benefit from your set, please read these Instructions before making any adjustments, and retain them for future reference.

Retain your purchase receipt also, and note down the model number and serial number of your set in the space provided on the rear cover of these instructions.

Visit our Panasonic Web Site <http://panasonic.net>

Table of Contents

Important Safety Notice	3	Reduces power consumption	30
Safety Precautions	4	Customizing the Input labels	31
Accessories	7	Display orientation	31
Accessories Supply	7	Setup for MULTI DISPLAY	32
Remote Control Batteries	7	How to Setup MULTI DISPLAY	32
Connections	8	ID Remote Control Function	33
PC Input Terminals connection	9	MULTI PIP Setup	34
SERIAL Terminals connection	10	Set up for Portrait	35
DVI-D connection	11	How to setup Portrait.....	35
COMPONENT / RGB connection	11	Setup for Input Signals	37
Power On / Off	12	Component / RGB-in select.....	37
Initial selections	14	YUV / RGB-in select.....	37
Selecting the input signal	14	Signal menu	38
Selecting the On-Screen Menu Language	14	3D Y/C Filter	38
Basic Controls	15	Colour system / Panasonic Auto	39
ASPECT Controls	17	Cinema reality	39
MULTI PIP	18	XGA Mode	39
Digital Zoom	20	Noise reduction	40
On-Screen Menu Displays	21	Sync	41
Adjusting Pos. /Size	22	SDI Through	41
Picture Adjustments	24	Input signal display.....	41
Advanced settings	25	Options Adjustments	42
Sound Adjustment	26	Weekly Command Timer	45
SDI sound Output.....	26	Shipping condition	46
PRESENT TIME Setup / Set up TIMER	27	Troubleshooting	47
PRESENT TIME Setup.....	27	List of Aspect Modes	48
Set up TIMER.....	27	Applicable Input Signals	49
Screensaver (For preventing image retention)	28	Command list of Weekly Command Timer	50
Setup of Screensaver Time	28	Specifications	51
Reduces screen image retention.....	29		
Side Panel Adjustment	29		

Trademark Credits

- VGA is a trademark of International Business Machines Corporation.
 - Macintosh is a registered trademark of Apple Computer, USA.
 - SVGA, XGA, SXGA and UXGA are registered trademarks of the video Electronics Standard Association.
- Even if no special notation has been made of company or product trademarks, these trademarks have been fully respected.

Note:

Do not allow a still picture to be displayed for an extended period, as this can cause a permanent image retention to remain on the Plasma Display.

Examples of still pictures include logos, video games, computer images, teletext and images displayed in 4:3 mode.

Important Safety Notice

WARNING

- 1) To prevent damage which may result in fire or shock hazard, do not expose this appliance to dripping or splashing.
Do not place containers with water (flower vase, cups, cosmetics, etc.) above the set. (including on shelves above, etc.)
No naked flame sources, such as lighted candles, should be placed on / above the set.
- 2) To prevent electric shock, do not remove cover. No user serviceable parts inside. Refer servicing to qualified service personnel.
- 3) Do not remove the earthing pin on the power plug. This apparatus is equipped with a three pin earthing-type power plug. This plug will only fit an earthing-type power outlet. This is a safety feature. If you are unable to insert the plug into the outlet, contact an electrician.
Do not defeat the purpose of the earthing plug.
- 4) To prevent electric shock, ensure the earthing pin on the AC cord power plug is securely connected.

CAUTION

This appliance is intended for use in environments which are relatively free of electromagnetic fields. Using this appliance near sources of strong electromagnetic fields or where electrical noise may overlap with the input signals could cause the picture and sound to wobble or cause interference such as noise to appear. To avoid the possibility of harm to this appliance, keep it away from sources of strong electromagnetic fields.

IMPORTANT: THE MOULDED PLUG

FOR YOUR SAFETY, PLEASE READ THE FOLLOWING TEXT CAREFULLY.

This display is supplied with a moulded three pin mains plug for your safety and convenience. A 10 amp fuse is fitted in this plug. Shall the fuse need to be replaced, please ensure that the replacement fuse has a rating of 10 amps and that it is approved by ASTA or BSI to BS1362.

Check for the ASTA mark  or the BSI mark  on the body of the fuse.

If the plug contains a removable fuse cover, you must ensure that it is refitted when the fuse is replaced.

If you lose the fuse cover the plug must not be used until a replacement cover is obtained.

A replacement fuse cover can be purchased from your local Panasonic dealer.

Do not cut off the mains plug.

Do not use any other type of mains lead except the one supplied with this display.

The supplied mains lead and moulded plug are designed to be used with this display to avoid interference and for your safety.

If the socket outlet in your home is not suitable, get it changed by a qualified electrician.

If the plug or mains lead becomes damaged, purchase a replacement from an authorized dealer.

WARNING : — THIS DISPLAY MUST BE EARTHED.

How to replace the fuse. Open the fuse compartment with a screwdriver and replace the fuse.

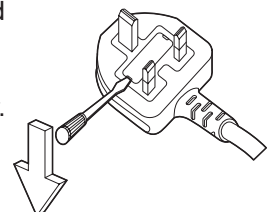

Safety Precautions

WARNING

■ Setup

This Plasma Display is for use only with the following optional accessories. Use with any other type of optional accessories may cause instability which could result in the possibility of injury.

(All of the following accessories are manufactured by Panasonic Corporation.)

- Speakers TY-SP42P8W-K (for TH-42PF11EK),
TY-SP50P8W-K (for TH-50PF11EK), TY-SP58P10WK (for TH-58PF11EK),
TY-SP65P11WK (for TH-65PF11EK)
- Pedestal TY-ST07-K (for TH-42PF11EK),
TY-ST08-K (for TH-42PF11EK, TH-50PF11EK),
TY-ST58-K (for TH-58PF11EK), TY-ST65P11-K (for TH-65PF11EK)
- Mobile stand TY-ST42PF3 (for TH-42PF11EK),
TY-ST58PF10 (for TH-42PF11EK, TH-50PF11EK, TH-58PF11EK)
- Wall-hanging bracket (vertical) TY-WK42PV7 (for TH-42PF11EK, TH-50PF11EK, TH-58PF11EK),
TY-WK65PV7 (for TH-65PF11EK)
- Wall-hanging bracket (angled) TY-WK42PR7 (for TH-42PF11EK, TH-50PF11EK, TH-58PF11EK),
TY-WK65PR8 (for TH-65PF11EK)
- Wall-hanging bracket (drawer type) TY-WK42DR1 (for TH-42PF11EK, TH-50PF11EK)
- Ceiling-hanging bracket TY-CE42PS7 (for TH-42PF11EK, TH-50PF11EK)
- BNC Component Video Terminal Board TY-42TM6A
- BNC Composite Video Terminal Board TY-42TM6B
- BNC Dual Video Terminal Board TY-FB9BD
- RCA Component Video Terminal Board TY-42TM6Z
- RCA Composite Video Terminal Board TY-42TM6V
- RGB Active Through Terminal Board TY-42TM6G
- PC Input Terminal Board TY-42TM6P
- Composite / Component Video Terminal Board .. TY-42TM6Y
- SDI Terminal Board TY-FB7SD
- HD-SDI Terminal Board TY-FB9HD
- HD-SDI Terminal Board with audio TY-FB10HD
- Dual Link HD-SDI Terminal Board TY-FB11DHD
- HDMI Terminal Board TY-FB8HM
- Dual HDMI Terminal Board TY-FB10HMD
- Scart Terminal Board TY-FB8SC
- Ir Through Terminal Board TY-FB9RT
- DVI-D Terminal Board TY-FB11DD
- Wireless Presentation Board TY-FB10WPE
- AV Terminal Box TY-TB10AV
- Touch Panel TY-TP42P10S (for TH-42PF11EK), TY-TP50P10S (for TH-50PF11EK),
TY-TP50P8-S (for TH-50PF11EK), TY-TP58P10S (for TH-58PF11EK),
TY-TP65P10S (for TH-65PF11EK)
- Touch Pen TY-TPEN6 (for TH-50PF11EK)
- Anti glare filter TY-AR42P9W (for TH-42PF11EK), TY-AR50P9W (for TH-50PF11EK),
TY-AR58P10W (for TH-58PF11EK), TY-AR65P9W (for TH-65PF11EK)

Always be sure to ask a qualified technician to carry out set-up.

Small parts can present choking hazard if accidentally swallowed. Keep small parts away from young children. Discard unneeded small parts and other objects, including packaging materials and plastic bags/sheets to prevent them from being played with by young children, creating the potential risk of suffocation.

Do not place the Plasma Display on sloped or unstable surfaces.

- The Plasma Display may fall off or tip over.

Do not place any objects on top of the Plasma Display.

- If water is spilled onto the Plasma Display or foreign objects get inside it, a short-circuit may occur which could result in fire or electric shock. If any foreign objects get inside the Plasma Display, please consult your local Panasonic dealer.

Transport only in upright position!

- Transporting the unit with its display panel facing upright or downward may cause damage to the internal circuitry.

Ventilation should not be impeded by covering the ventilation openings with items such as newspapers, table cloths and curtains.

For sufficient ventilation;

If using the pedestal (optional accessory), leave a space of 10 cm or more at the top, left and right, and 7 cm or more at the rear, and also keep the space between the bottom of the display and the floor surface.

If using some other setting-up method, follow the manual of it. (If there is no specific indication of installation dimension in the installation manual, leave a space of 10 cm or more at the top, bottom, left and right, and 7 cm or more at the rear.)

■ When using the Plasma Display

The Plasma Display is designed to operate on 220 - 240 V AC, 50/60 Hz.

Do not cover the ventilation holes.

- Doing so may cause the Plasma Display to overheat, which can cause fire or damage to the Plasma Display.

Do not stick any foreign objects into the Plasma Display.

- Do not insert any metal or flammable objects into the ventilations holes or drop them onto the Plasma Display, as doing so can cause fire or electric shock.

Do not remove the cover or modify it in any way.

- High voltages which can cause severe electric shocks are present inside the Plasma Display. For any inspection, adjustment and repair work, please contact your local Panasonic dealer.

Ensure that the mains plug is easily accessible.

An apparatus with CLASS I construction shall be connected to a mains socket outlet with a protective earthing connection.

Do not use any power supply cord other than that provided with this unit.

- Doing so may cause fire or electric shocks.

Securely insert the power supply plug as far as it will go.

- If the plug is not fully inserted, heat may be generated which could cause fire. If the plug is damaged or the wall socket is loose, they shall not be used.

Do not handle the power supply plug with wet hands.

- Doing so may cause electric shocks.

Do not do anything that may damage the power cable. When disconnecting the power cable, pull on the plug body, not the cable.

- Do not damage the cable, make any modifications to it, place heavy objects on top of it, heat it, place it near any hot objects, twist it, bend it excessively or pull it. To do so may cause fire and electric shock. If the power cable is damaged, have it repaired at your local Panasonic dealer.

If the Plasma Display is not going to be used for any prolonged length of time, unplug the power supply plug from the wall outlet.

■ If problems occur during use

If a problem occurs (such as no picture or no sound), or if smoke or an abnormal odour starts to come out from the Plasma Display, immediately unplug the power supply plug from the wall outlet.

- If you continue to use the Plasma Display in this condition, fire or electric shock could result. After checking that the smoke has stopped, contact your local Panasonic dealer so that the necessary repairs can be made. Repairing the Plasma Display yourself is extremely dangerous, and shall never be done.

If water or foreign objects get inside the Plasma Display, if the Plasma Display is dropped, or if the cabinet becomes damages, disconnect the power supply plug immediately.

- A short circuit may occur, which could cause fire. Contact your local Panasonic dealer for any repairs that need to be made.

Safety Precautions



CAUTION

■ When using the Plasma Display

Do not bring your hands, face or objects close to the ventilation holes of the Plasma Display.

- Heated air comes out from the ventilation holes at the top of Plasma Display will be hot. Do not bring your hands or face, or objects which cannot withstand heat, close to this port, otherwise burns or deformation could result.

Be sure to disconnect all cables before moving the Plasma Display.

- If the Plasma Display is moved while some of the cables are still connected, the cables may become damaged, and fire or electric shock could result.

Disconnect the power supply plug from the wall socket as a safety precaution before carrying out any cleaning.

- Electric shocks can result if this is not done.

Clean the power cable regularly to prevent it becoming dusty.

- If dust built up on the power cord plug, the resultant humidity can damage the insulation, which could result in fire. Pull the power cord plug out from the wall outlet and wipe the mains lead with a dry cloth.

Do not burn or breakup batteries.

- Batteries must not be exposed to excessive heat such as sunshine, fire or the like.

This Plasma Display radiates infrared rays, therefore it may affect other infrared communication equipment. Install your infrared sensor in a place away from direct or reflected light from your Plasma Display.

Cleaning and maintenance

The front of the display panel has been specially treated. Wipe the panel surface gently using only a cleaning cloth or a soft, lint-free cloth.

- If the surface is particularly dirty, wipe with a soft, lint-free cloth which has been soaked in pure water or water in which neutral detergent has been diluted 100 times, and then wipe it evenly with a dry cloth of the same type until the surface is dry.
- Do not scratch or hit the surface of the panel with fingernails or other hard objects, otherwise the surface may become damaged. Furthermore, avoid contact with volatile substances such as insect sprays, solvents and thinner, otherwise the quality of the surface may be adversely affected.

If the cabinet becomes dirty, wipe it with a soft, dry cloth.

- If the cabinet is particularly dirty, soak the cloth in water to which a small amount of neutral detergent has been added and then wring the cloth dry. Use this cloth to wipe the cabinet, and then wipe it dry with a dry cloth.
- Do not allow any detergent to come into direct contact with the surface of the Plasma Display. If water droplets get inside the unit, operating problems may result.
- Avoid contact with volatile substances such as insect sprays, solvents and thinner, otherwise the quality of the cabinet surface may be adversely affected or the coating may peel off. Furthermore, do not leave it for long periods in contact with articles made from rubber or PVC.

Accessories

Accessories Supply

Check that you have the accessories and items shown



Operating Instruction book

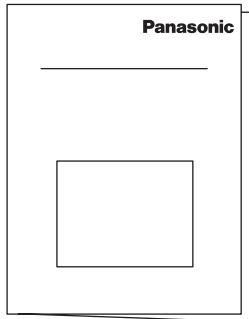

Remote Control Transmitter
EUR7636090R



Batteries for the Remote Control Transmitter
(2 × R6 (UM3) Size)



Power supply cord

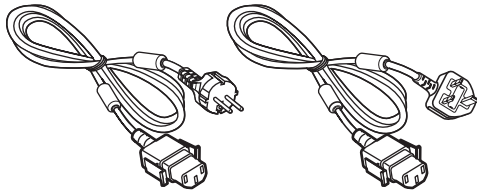

Fixing band × 1

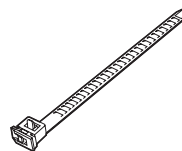

Remote Control Batteries

Requires two R6 batteries.

1. Pull and hold the hook, then open the battery cover.

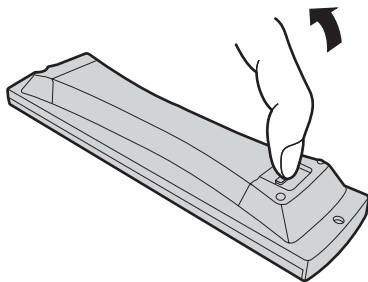

2. Insert batteries - note correct polarity (+ and -).

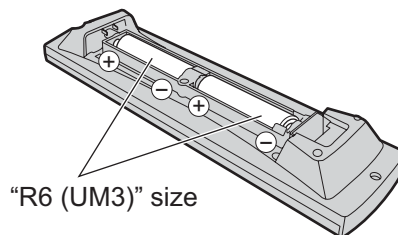

3. Replace the cover.

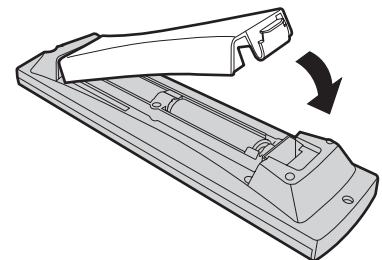

Helpful Hint:

For frequent remote control users, replace old batteries with Alkaline batteries for longer life.

⚠ Precaution on battery use

Incorrect installation can cause battery leakage and corrosion that will damage the remote control transmitter. Disposal of batteries should be in an environment-friendly manner.

Observe the following precaution:

1. Batteries shall always be replaced as a pair. Always use new batteries when replacing the old set.
2. Do not combine a used battery with a new one.
3. Do not mix battery types (example: "Zinc Carbon" with "Alkaline").
4. Do not attempt to charge, short-circuit, disassemble, heat or burn used batteries.
5. Battery replacement is necessary when remote control acts sporadically or stops operating the Plasma Display set.
6. Do not burn or breakup batteries.
Batteries must not be exposed to excessive heat such as sunshine, fire or the like.

Connections

When connecting the speakers, be sure to use only the optional accessory speakers. Refer to the speaker's Installation Manual for details on speaker installation.

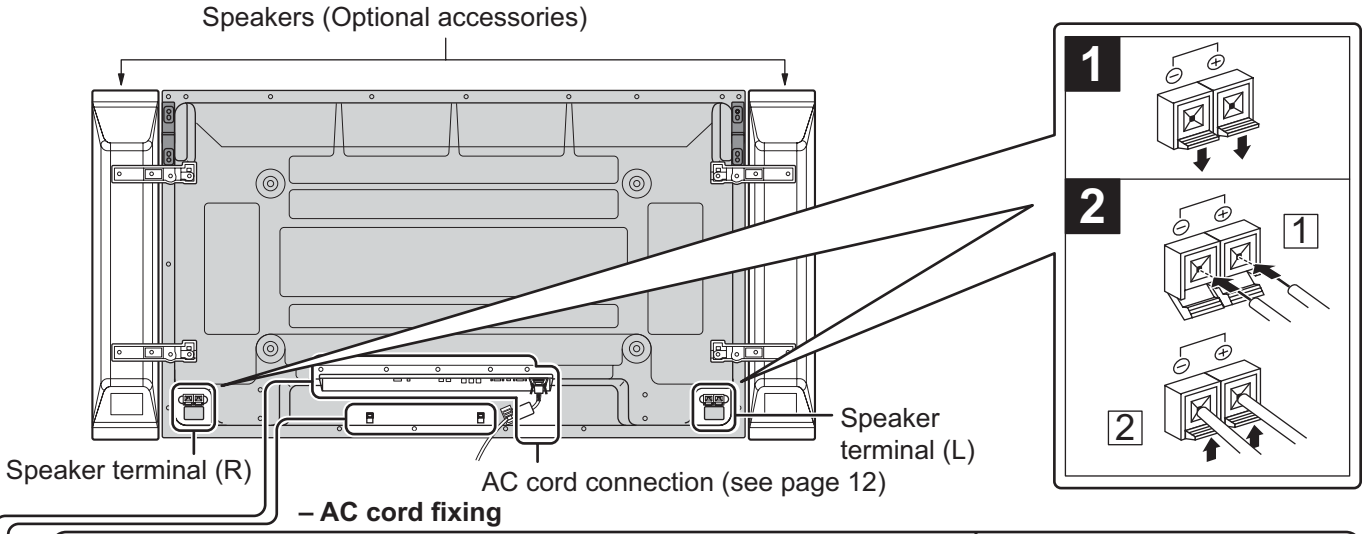

- AC cord fixing

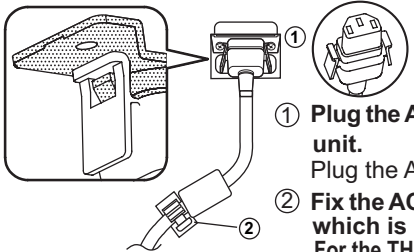

- ① **Plug the AC cord into the display unit.**
Plug the AC cord until it clicks.
- ② **Fix the AC cord with the clumper which is attached to the unit.**
For the TH-42PF11EK, TH-58PF11EK: Clumpers are not installed to this unit. Ensure there is sufficient slack in the AC cord and firmly bind with the supplied cable fixing band, etc.

Note:
Make sure that the AC cord is locked on both the left and right sides.

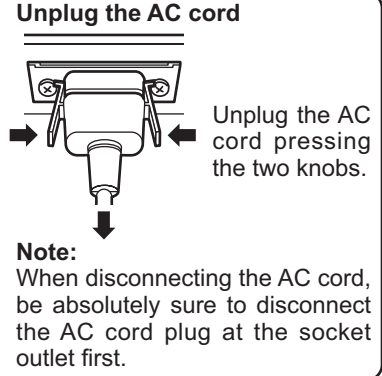
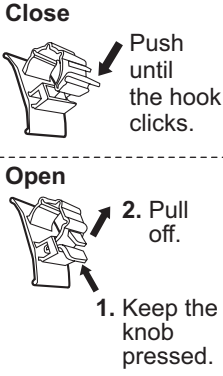

- Cable fixing band

Secure any excess cables with band as required.

Note:

One fixing band is supplied with this unit. In case of securing cables at two positions, please purchase it separately.

Pass the attached cable fixing band through the clip as shown in the figure.

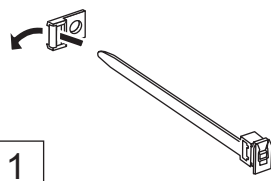

To secure cables connected to Terminals, wrap the cable fixing band around them then pass the pointed end through the locking block, as shown in the figure. **While ensuring there is sufficient slack in cables to minimize stress (especially in the power cord), firmly bind all cables with the supplied fixing band.**

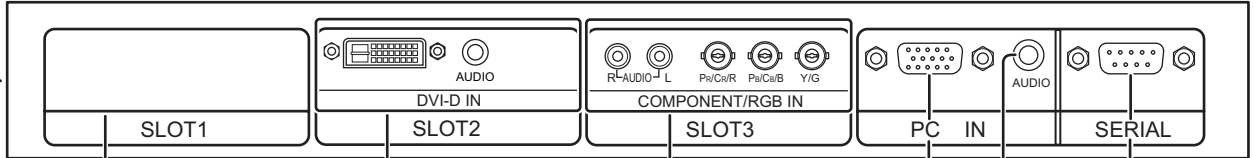
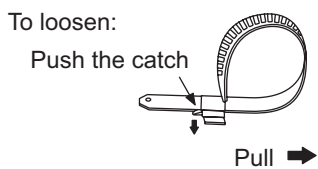
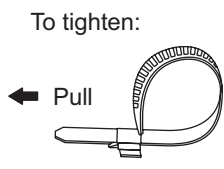
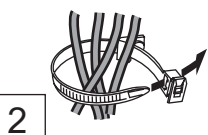

Optional Terminal Board Insert Slot (covered)

DVI-D IN Terminals (equivalent of DVI-D Terminal Board (TY-FB11DD)) (see page 11)

COMPONENT/RGB IN and Audio IN Terminals (equivalent of BNC Component Video Terminal Board (TY-42TM6A)) (see page 11)

From EXTERNAL monitor terminal on Computer (see page 9)

From SERIAL Terminal on Computer (see page 10)

Note: At factory shipment, Terminal boards are installed in SLOT 2 and SLOT 3.

PC Input Terminals connection

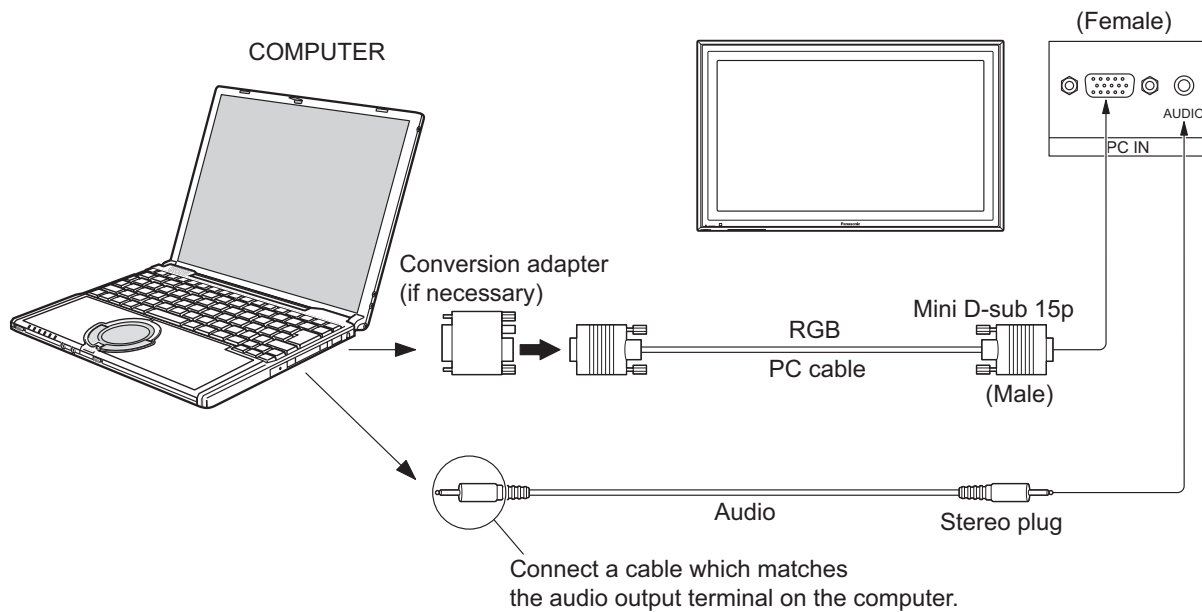

Notes:

- Due to space limitations, occasionally you may have trouble connecting Mini D-sub 15P cable with ferrite core to PC input Terminal.
- With regard to the typical PC input signals that are described in the applicable input signals list (see page 49), adjustment values such as for the standard picture positions and sizes have already been stored in this unit. You can add up to eight PC input signal types that are not included in the list.
- Computer signals which can be input are those with a horizontal scanning frequency of 15 to 110 kHz and vertical scanning frequency of 48 to 120 Hz. (However, the image will not be displayed properly if the signals exceed 1,200 lines.)
- The display resolution is a maximum of 1,440 × 1,080 dots when the aspect mode is set to “4:3”, and 1,920 × 1,080 dots when the aspect mode is set to “16:9”. If the display resolution exceeds these maximums, it may not be possible to show fine detail with sufficient clarity.
- The PC input terminals are DDC2B-compatible. If the computer being connected is not DDC2B-compatible, you will need to make setting changes to the computer at the time of connection.
- Some PC models cannot be connected to the set.
- There is no need to use an adapter for computers with DOS/V compatible Mini D-sub 15P terminal.
- The computer shown in the illustration is for example purposes only.
- Additional equipment and cables shown are not supplied with this set.
- Do not set the horizontal and vertical scanning frequencies for PC signals which are above or below the specified frequency range.
- Component Input is possible with the pin 1, 2, 3 of the Mini D-sub 15P Connector.
- To use sync input VBS signals, use the connector which incorporates a 75-ohm termination resistance and which is available on the market, for the connection of the HD connector where the VBS signals are to be input.
- Change the “Component/RGB-in select” setting in the “Setup” menu to “Component” (when Component signal connection) or “RGB” (when RGB signal connection). (see page 37)

Signal Names for Mini D-sub 15P Connector

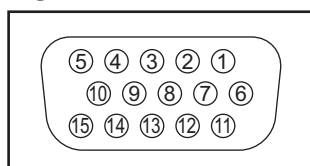

Pin Layout for PC Input Terminal

Pin No.	Signal Name	Pin No.	Signal Name	Pin No.	Signal Name
①	R (P _R /C _R)	⑥	GND (Ground)	⑪	NC (not connected)
②	G (Y)	⑦	GND (Ground)	⑫	SDA
③	B (P _B /C _B)	⑧	GND (Ground)	⑬	HD/SYNC
④	NC (not connected)	⑨	+5 V DC	⑭	VD
⑤	GND (Ground)	⑩	GND (Ground)	⑮	SCL

SERIAL Terminals connection

The SERIAL terminal is used when the Plasma Display is controlled by a computer.

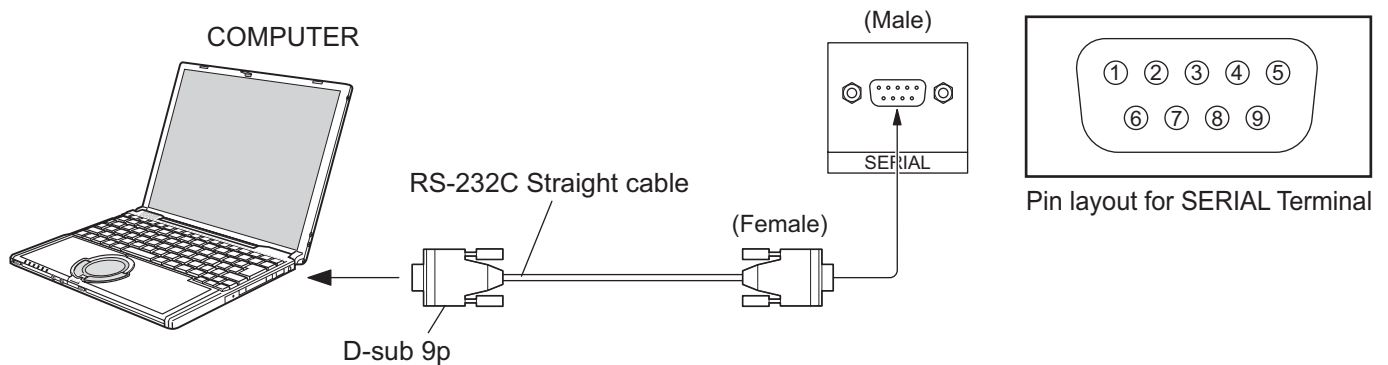

Notes:

- Use the RS-232C straight cable to connect the computer to the Plasma Display.
- The computer shown is for example purposes only.
- Additional equipment and cables shown are not supplied with this set.

The SERIAL terminal conforms to the RS-232C interface specification, so that the Plasma Display can be controlled by a computer which is connected to this terminal.

The computer will require software which allows the sending and receiving of control data which satisfies the conditions given below. Use a computer application such as programming language software. Refer to the documentation for the computer application for details.

Signal names for D-sub 9P connector

Pin No.	Details
②	R X D
③	T X D
⑤	GND
④ • ⑥	Non use
⑦ ⑧	(Shorted in this set)
① • ⑨	NC

These signal names are those of computer specifications.

Communication parameters

Signal level	RS-232C compliant
Synchronization method	Asynchronous
Baud rate	9600 bps
Parity	None
Character length	8 bits
Stop bit	1 bit
Flow control	-

Basic format for control data

The transmission of control data from the computer starts with a STX signal, followed by the command, the parameters, and lastly an ETX signal in that order. If there are no parameters, then the parameter signal does not need to be sent.

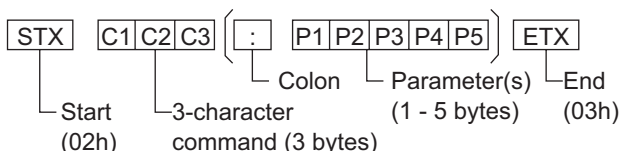

Notes:

- If multiple commands are transmitted, be sure to wait for the response for the first command to come from this unit before sending the next command.
- If an incorrect command is sent by mistake, this unit will send an "ER401" command back to the computer.
- SL1A, SL1B, SL2A and SL2B of Command IMS are available only when a dual input terminal board is attached.

Command

Command	Parameter	Control details
PON	None	Power ON
POF	None	Power OFF
AVL	**	Volume 00 - 63
AMT	0	Audio MUTE OFF
	1	Audio MUTE ON
IMS	None	Input select (toggle)
	SL1	Slot1 input
	SL2	Slot2 input
	SL3	Slot3 input
	PC1	PC input
	SL1A	Slot1 input (INPUT1A)
	SL1B	Slot1 input (INPUT1B)
	SL2A SL2B	Slot2 input (INPUT2A) Slot2 input (INPUT2B)
DAM	None	Screen mode select (toggle)
	ZOOM	Zoom1
	FULL	16:9
	JUST	Just
	NORM	4:3
	SELF	Panasonic Auto
	ZOM2	Zoom2
	ZOM3	Zoom3
	SJST	Just
	SNOM	4:3
	SFUL	4:3 Full
	14:9	14:9

With the power off, this display responds to PON command only.

DVI-D connection

This unit has terminal boards equivalent to DVI-D Terminal Board (TY-FB11DD) and BNC Component Video Terminal Board (TY-42TM6A) as standard equipment.

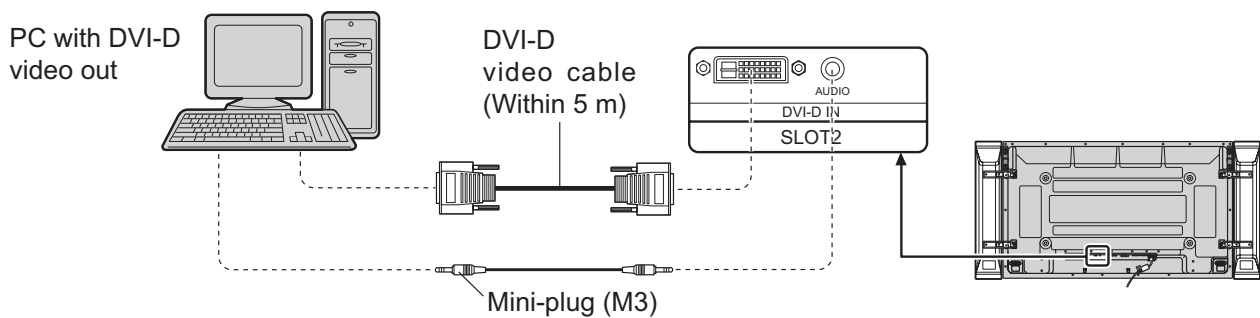

DVI-D Input Connector Pin Layouts

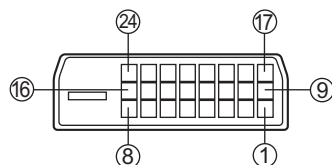

Connection port view

Pin No.	Signal Name	Pin No.	Signal Name
①	T.M.D.S. data 2-	⑬	
②	T.M.D.S. data 2+	⑭	+5 V DC
③	T.M.D.S. data 2 shield	⑮	Ground
④		⑯	Hot plug detect
⑤		⑰	T.M.D.S. data 0-
⑥	DDC clock	⑱	T.M.D.S. data 0+
⑦	DDC data	⑲	T.M.D.S. data 0 shield
⑧		⑳	
⑨	T.M.D.S. data 1-	㉑	
⑩	T.M.D.S. data 1+	㉒	T.M.D.S. clock shield
⑪	T.M.D.S. data 1 shield	㉓	T.M.D.S. clock+
⑫		㉔	T.M.D.S. clock-

Notes:

- Additional equipment, cables and adapter plugs shown are not supplied with this set.
- Refer to page 49 for applicable input signal.
- Use the DVI-D cable complying with the DVI standard. Image deterioration may occur depending on the length or the quality of the cable.

COMPONENT / RGB connection

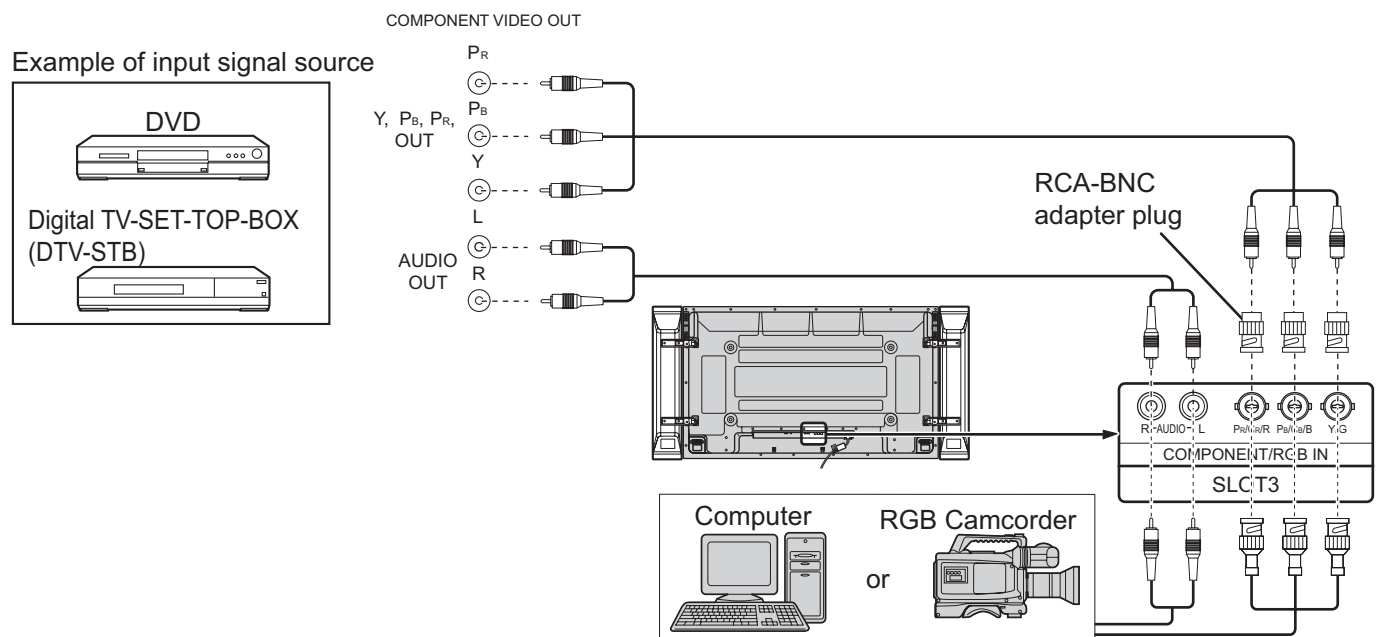

Notes:

- Change the "Component/RGB-in select" setting in the "Setup" menu to "Component" (when Component signal connection) or "RGB" (when RGB signal connection). (see page 37)
- Additional equipment, cables and adapter plugs shown are not supplied with this set.
- Sync on G signal is needed. (see page 41)

Power On / Off

Connecting the AC cord plug to the Plasma Display.

Fix the AC cord plug securely to the Plasma Display with the clamper. (see page 8)

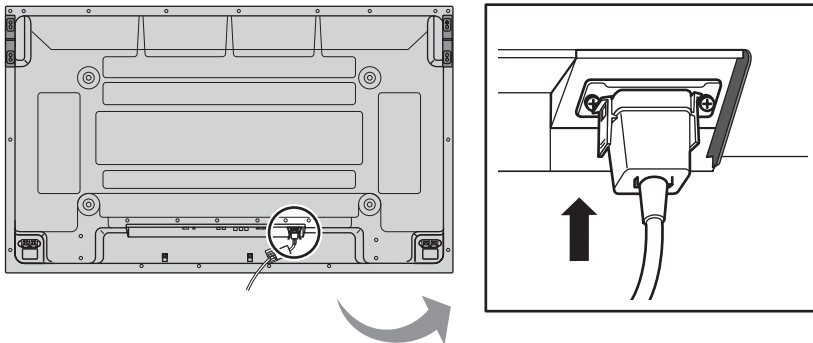

Connecting the plug to the Wall Outlet

Notes:

- Main plug types vary between countries. The power plug shown at right may, therefore, not be the type fitted to your set.
- When disconnecting the AC cord, be absolutely sure to disconnect the AC cord plug at the socket outlet first.

Press the Power switch on the Plasma Display to turn the set on: Power-On.

Power Indicator: Green

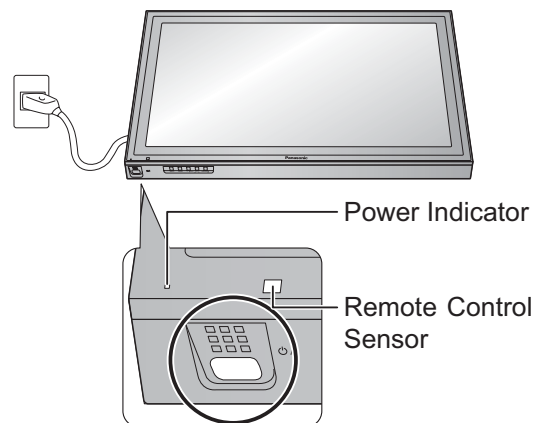

OFF



Press the  button on the remote control to turn the Plasma Display off.

Power Indicator: Red (standby)



Press the  button on the remote control to turn the Plasma Display on.

Power Indicator: Green

Turn the power to the Plasma Display off by pressing the  switch on the unit, when the Plasma Display is on or in standby mode.

Note:

During operation of the power management function, the power indicator turns orange in the power off state.

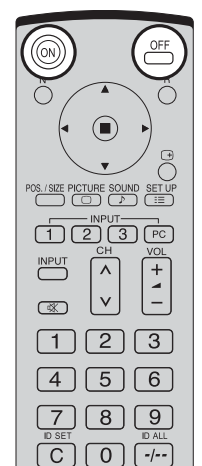

When first switching on the unit

Following screen will be displayed when the unit is turned on for the first time. Select the items with the remote control. Unit buttons are invalid.

OSD Language

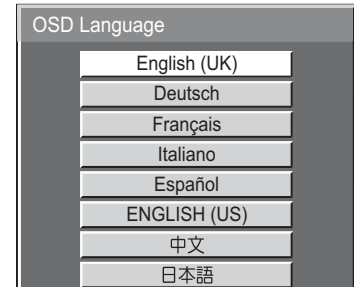
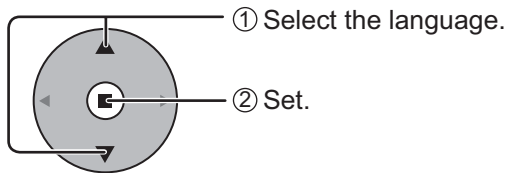

PRESENT TIME Setup

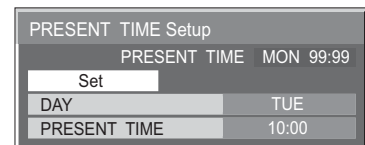
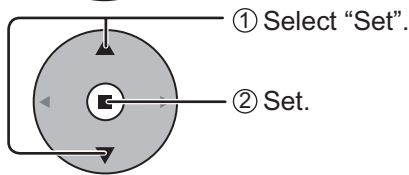
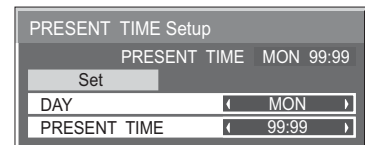
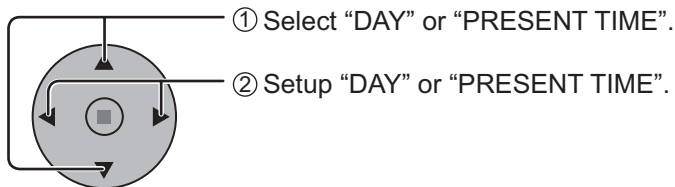

Display orientation

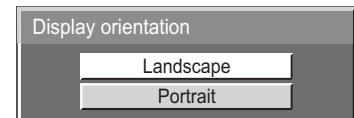
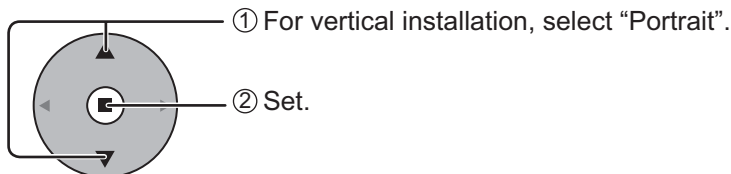

Notes:

- Once the items are set, the screens won't be displayed when switching on the unit next time.
- After the setting, the items can be changed in the following menus.
OSD Language (see page 14)
PRESENT TIME Setup (see page 27)
Display orientation (see page 31)

From the second time on, the below screen is displayed for a while (setting condition is an example).

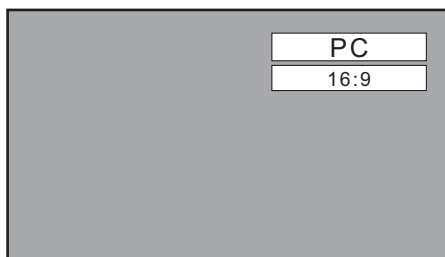

Initial selections

Selecting the input signal

Select the input signals to be connected by installing the optional Terminal Boards.

INPUT  Press to select the input signal to be played back from the equipment which has been connected to the Plasma Display.

Input signals will change as follows:

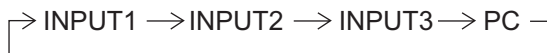

INPUT
 Press the INPUT "1", "2", "3" or "PC" input mode selection button to select the input mode. This button is used to switch directly to INPUT mode. These buttons can only display the slot which is installed. If you press the button whose slot is not installed, it automatically displays the current input signal. When a dual input terminal board is attached, A or B is displayed depending on the selected input signal. (Ex. INPUT1A, INPUT1B)

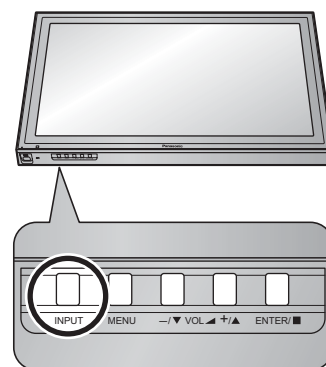
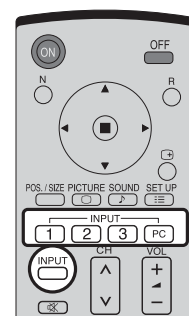

Notes:

- Selecting is also possible by pressing the INPUT button on the unit.
- Input terminal will not be selected if the terminal board is not installed into the SLOT.
- Select to match the signals from the source connected to the component/RGB input terminals. (see page 37)
- In two-screen display, the same input mode cannot be selected for the main picture and sub picture.
- Image retention (image lag) may occur on the plasma display panel when a still picture is kept on the panel for an extended period. The function that darkens the screen slightly is activated to prevent image retention (see page 47), but this function is not the perfect solution to image retention.

Selecting the On-Screen Menu Language

SET UP  Press to display the Setup menu.

 Press to select the OSD Language.

 Press to select your preferred language.

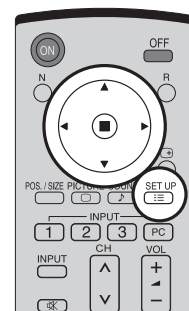
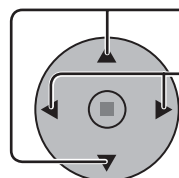

Selectable languages

- English(UK)
- Deutsch
- Français
- Italiano
- Español
- ENGLISH(US)
- 中文.....(Chinese)
- 日本語.....(Japanese)

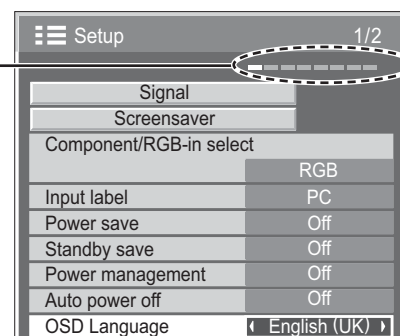

Basic Controls

Main Unit

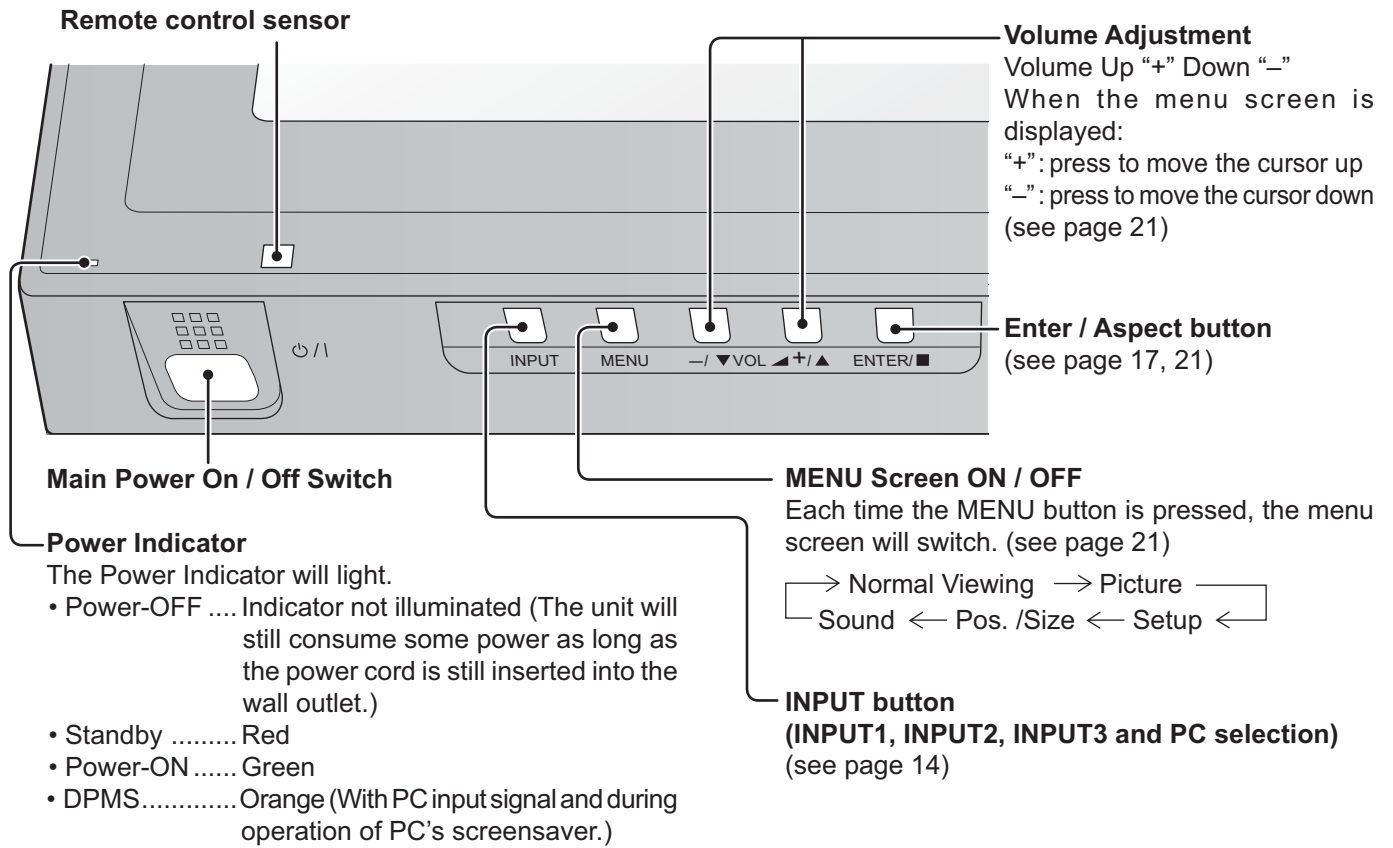

Remote Control Transmitter

R button (see page 21)

Press the R button to return to previous menu screen.

Standby (ON / OFF) button

The Plasma Display must first be plugged into the wall outlet and turned on at the power switch (see page 12). Press ON to turn the Plasma Display On, from Standby mode. Press OFF to turn the Plasma Display Off to Standby mode.

N button

(see page 23, 24, 25, 26)

POSITION buttons

ACTION button

Press to make selections.

POS. /SIZE button

(see page 22)

PICTURE button

(see page 24)

INPUT button

Press to select INPUT1, INPUT2, INPUT3 and PC input SLOTS sequentially. (see page 14) When a dual input terminal board is attached, A or B is displayed depending on the selected input signal. (Ex. INPUT1A, INPUT1B)

Sound mute On / Off

Press this button to mute the sound. Press again to reactivate sound. Sound is also reactivated when power is turned off or volume level is changed.

Numeric buttons

(see page 33)

ASPECT button

Press to adjust the aspect.

SURROUND button

The surround setting switches on and off each time the SURROUND button is pressed.

The benefits of surround sound are enormous. You can be completely enveloped in sound; just as if you were at a concert hall or cinema.

Note:

The surround settings are memorized separately for each Sound Mode (Normal, Dynamic, Clear).

Status button

Press the "Status" button to display the current system status.

- ① Input label
- ② Aspect mode (see page 17)
- ③ Off timer

The off timer indicator is displayed only when the off timer has been set.

- ④ Clock display (see page 44)

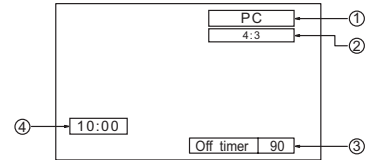

SET UP button (see page 21)

SOUND button (see page 26)

DIRECT INPUT buttons

Press the INPUT "1", "2", "3" or "PC" input mode selection button to select the INPUT mode. (see page 14) This button is used to switch directly to INPUT mode.

Volume Adjustment

Press the Volume Up "+" or Down "-" button to increase or decrease the sound volume level.

Channel Adjustment

This button cannot be used for this model.

OFF TIMER button

The Plasma Display can be preset to switch to stand-by after a fixed period. The setting changes to 30 minutes, 60 minutes, 90 minutes and 0 minutes (off timer cancelled) each time the button is pressed.

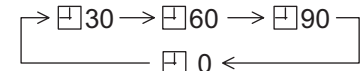

When three minutes remain, "OFF TIMER 3" will flash.

The off timer is cancelled if a power interruption occurs.

Remote ID lock (see page 33)

Digital Zoom (see page 20)

MULTI Window buttons

(see page 18)

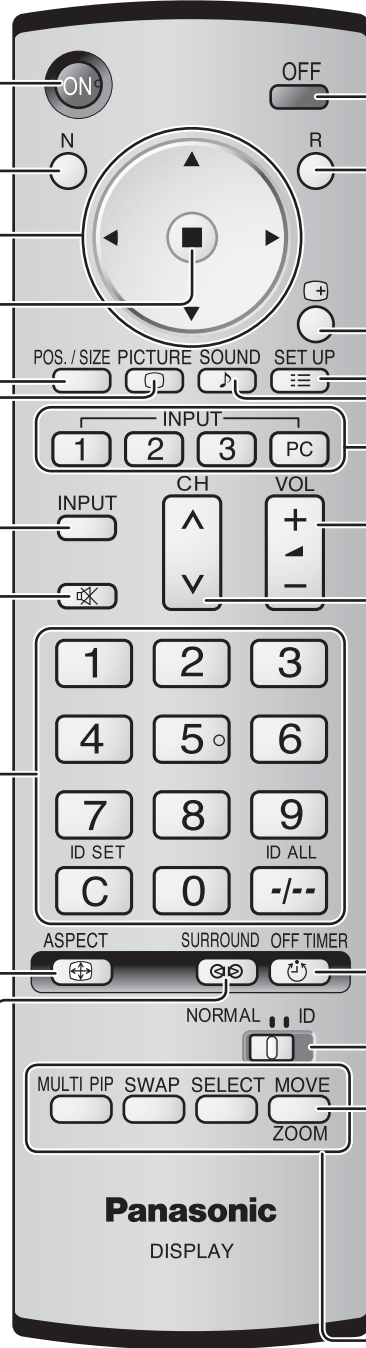

On ← → Off

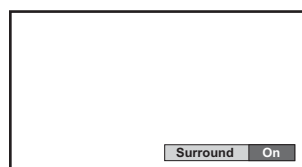

ASPECT Controls

The Plasma Display will allow you to enjoy viewing the picture at its maximum size, including wide screen cinema format picture.

Note:

Be aware that if you put the display in a public place for commercial purposes or a public showing and then use the aspect mode select function to shrink or expand the picture, you may be violating the copyright under copyright law. It is prohibited to show or alter the copyrighted materials of other people for commercial purposes without the prior permission of the copyright holder.

ASPECT



Press repeatedly to move through the aspect options:

For details about the aspect mode, please see "List of Aspect Modes" (page 48).

For VIDEO (S VIDEO) signal input:

→ 4:3 → Zoom1 → Zoom2 → Zoom3
Just ← 14:9 ← 16:9 ← Panasonic Auto ←

[from the unit]

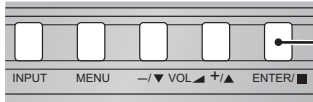

Note:

When selecting an input slot that attaches BNC Dual Video Terminal Board (TY-FB9BD), Panasonic Auto cannot be selected.

The aspect mode changes each time the ENTER button is pressed.

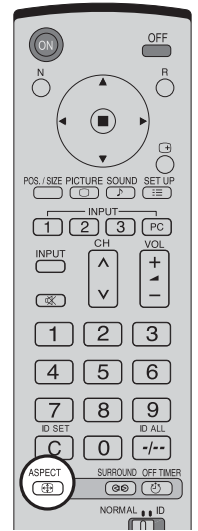

For PC signal input:

→ 4:3 → Zoom → 16:9 ←

For SD signal input (525 (480) / 60i • 60p, 625 (575) / 50i • 50p):

→ 4:3 → Zoom1 → Zoom2 → Zoom3 → 16:9 → 14:9 → Just ←

For HD signal input [1125 (1080) / 60i • 50i • 60p • 50p • 24p • 25p • 30p • 24sF, 1250 (1080) / 50i, 750 (720) / 60p • 50p]:

→ 4:3 → 4:3 Full → Zoom1 → Zoom2
Just ← 14:9 ← 16:9 ← Zoom3 ←

[During MULTI PIP Operations]

- Picture and Picture, Picture in Picture : → 4:3 → 16:9 ←
- Others : Aspect switching is not possible.

Notes:

- Panasonic Auto can be selected only during Video signal input.
- The aspect mode is memorized separately for each input terminal.
- Do not allow the picture to be displayed in 4:3 mode for an extended period, as this can cause a permanent image retention on the Plasma Display Panel.

Panasonic Auto

The display will automatically become enlarged (depending on the picture source), allowing you to view the picture at its maximum size.

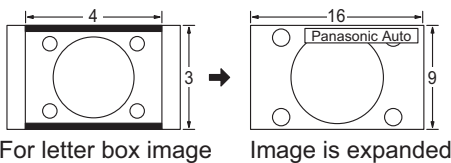

For letter box image

Image is expanded

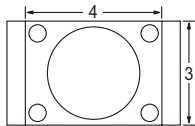

For a 4:3 image

Changes in accordance with the Panasonic Auto mode setting (see page 39).

Notes:

- Panasonic Auto mode is designed to automatically adjust the aspect ratio to handle a mix of 16:9 and 4:3 program material. Certain 4:3 program material, such as stock market data screens, may occasionally cause the image size to change unexpectedly. When viewing such programs, it is recommended that the ASPECT be set to 4:3.
- If adjusting the Picture V-Pos/V-Size in Panasonic Auto with 16:9 mode, the adjustment is not memorized. When exiting the mode, the screen will return to a former adjustment.

All Aspect mode

Set "All Aspect" to "On" in Options menu to enable the extended aspect mode (page 44). When All Aspect mode, the aspect mode of pictures is switched as follows. For details about the aspect mode, please see "List of Aspect Modes" (page 48)

For VIDEO (S VIDEO) signal input:

→ 4:3 → Zoom1 → Zoom2 → Zoom3 → Panasonic Auto → 16:9 → 14:9 → Just ←

Note: When selecting an input slot that attaches BNC Dual Video Terminal Board (TY-FB9BD), Panasonic Auto cannot be selected.

For PC signal input:

→ 4:3 → Zoom → 16:9 ←

For SD signal input (525 (480) / 60i • 60p, 625 (575) / 50i • 50p):

→ 4:3 → Zoom1 → Zoom2 → Zoom3 → 16:9 → 14:9 → Just ←

For HD signal input [1125 (1080) / 60i • 50i • 60p • 50p • 24p • 25p • 30p • 24sF, 1250 (1080) / 50i, 750 (720) / 60p • 50p]:

→ 4:3 Full → Zoom1 → Zoom2 → Zoom3 → 16:9 → 14:9 → Just1 → Just2 → 4:3 (1) → 4:3 (2) ←

MULTI PIP

You can display two pictures, such as a video image and computer image, in a two-screen display. (Use the remote control for this operation. It cannot be performed with the buttons on the main unit.)

MULTI PIP Setup

Set the functions and mode for two-screen display in "MULTI PIP Setup" in the Setup menu. (see page 34)

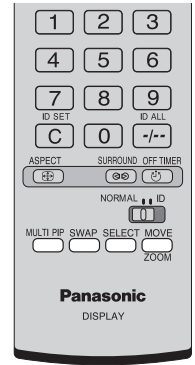

Selecting the Display Mode

MULTI PIP  Each time this button is pressed, the screen changes.

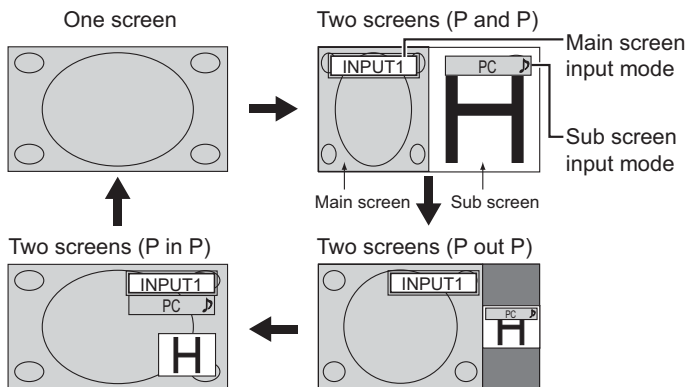

Note: The screen changes in the same way when "Display Mode" in "MULTI PIP Setup" is changed. (see page 34)

During PIP:

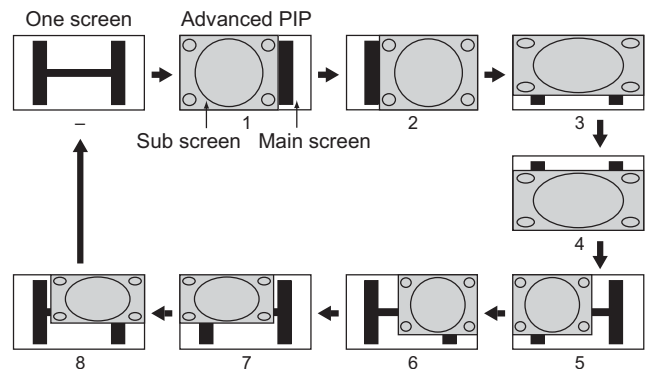

During Advanced PIP:



Note: ASPECT  and MOVE  ZOOM  button operations are not available during advanced PIP.

During Blend PIP (Composite Screen Function):

A composite picture is displayed with the sub screen positioned over the main screen. For example, text data such as a computer image can be displayed as a caption over a movie or still image.

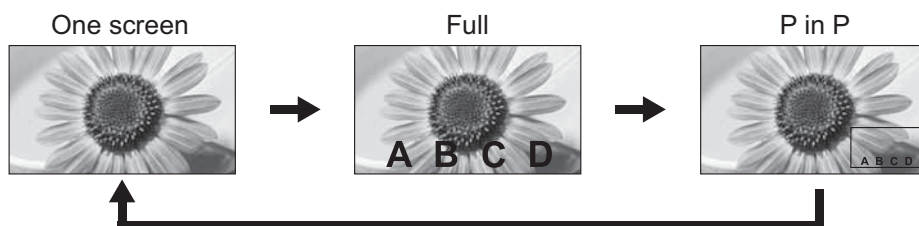

Transparent Function and Insertion Function:

Two functions are available for blend PIP: the transparent function and the insertion function. Set these functions with "Transparency" or "Insert" in "MULTI PIP Setup". (see page 34)

Transparent Function:

Data such as text are displayed transparently on the background image.



Note:

Be aware that if you put the display in a public place for commercial purposes or a public showing and then use the blend PIP function to make a composite screen display, you may be violating the copyright under copyright law. It is prohibited to show or alter the copyrighted materials of other people for commercial purposes without the prior permission of the copyright holder.

Insertion Function:

The sub screen image is divided into transparent and non-transparent areas, and only the non-transparent areas are inserted and displayed on the background image.



Swapping Screens

SWAP

 Each time this button is pressed, the main screen and sub screen are swapped.

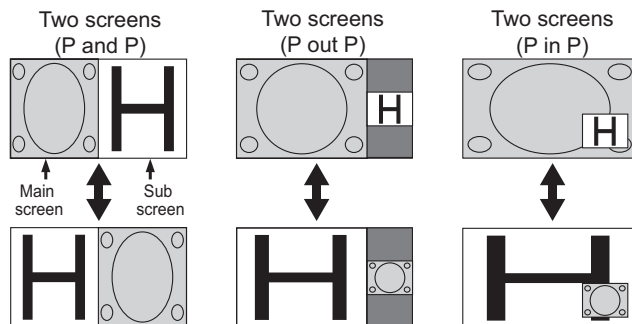

Selecting the Target Screen for Operations

SELECT

 Each time this button is pressed, the target screen for operations changes.

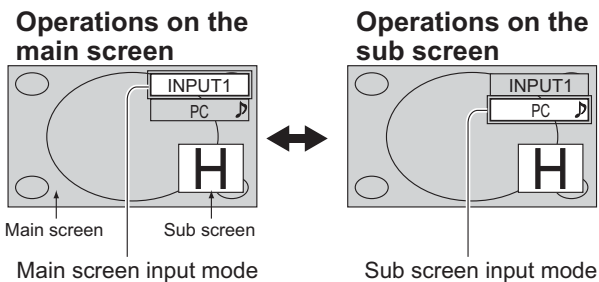

Notes:

- When operations are performed for the sub screen, the sub screen audio is played.
- If no operations are performed, the operation target returns to the main screen after about 5 seconds. You can also return to main screen operations by operating the remote control buttons (except for ).

Selecting the Sub Screen Position (During P in P Display)

MOVE

 Each time this button is pressed, the sub screen position changes.

ZOOM

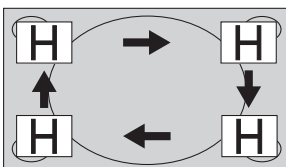

Note:

Some sub screen positions may hide the display of the menu screen.

Notes:

- Do not use the two-screen display for a long time. It will cause a permanent image retention to remain on the screen.
- If "INPUT lock" in Options menu is set to other than "Off", MULTI PIP function isn't available.
- Sound output is from the picture which is selected in Audio OUT (PIP) (see page 26).
- In two-screen display, the same input mode cannot be selected for the main picture and sub picture.
- The main picture and sub picture are processed by different circuits, resulting in a slight difference in the clarity of the pictures. There may also be a difference in the picture quality of the sub picture depending on the type of signals displayed on the main picture and depending on the two-screen display mode.
- Due to the small dimensions of the sub pictures, these sub pictures cannot be shown in detail.
- Computer screen picture is displayed in a simplified format, and it may not be possible to discern details on them satisfactorily.
- Following combinations of two analog signals cannot be displayed simultaneously;
 - Component - Component, Component - PC (RGB), PC (RGB) - Component, PC (RGB) - PC (RGB)
- 2k1k signals that are received with the Dual Link HD-SDI Terminal Board (TY-FB11DHD) cannot be displayed in two-screen display.

Digital Zoom

This displays an enlargement of the designated part of the displayed image.

1 Display the operation guide.

MOVE ZOOM — Press to access Digital Zoom.
The operation guide will be displayed.

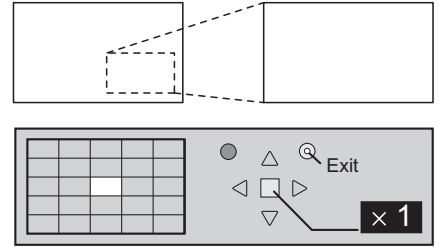

During Digital Zoom, only the following buttons can be operated.

[Remote control]

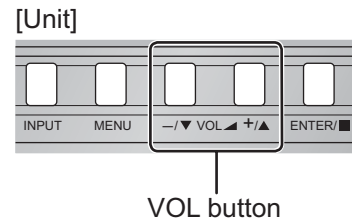
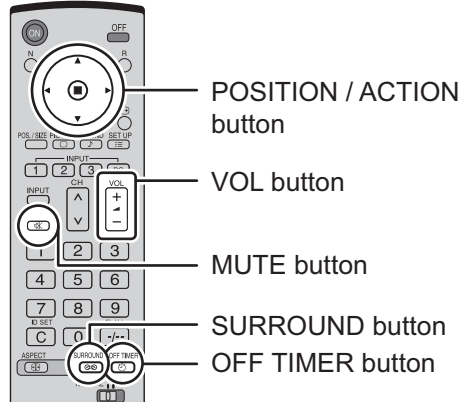

2 Select the area of the image to be enlarged.

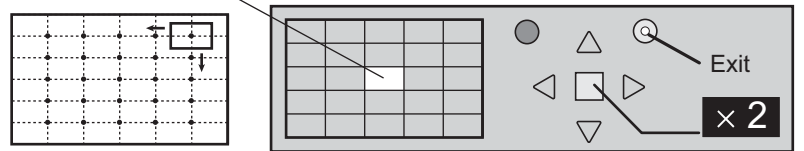
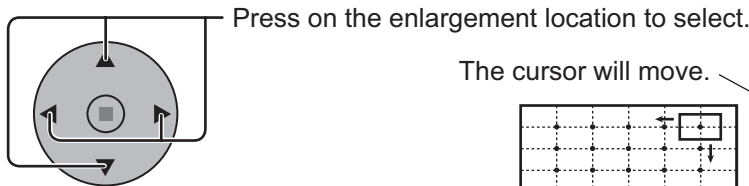

3 Select the magnification required for the enlarged display.

Each time this is pressed, the magnification factor changes.
This is shown in the image being displayed.

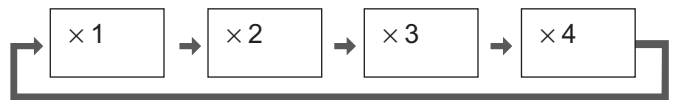
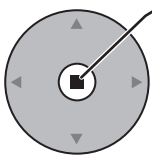

4 Return to normal display (quit Digital Zoom).

R — Press to exit from the Digital Zoom.

Notes:

- When power goes OFF (including “Off Timer” operation), Digital Zoom terminates.
- The Digital Zoom function cannot be selected while in the following operation state:
 - “Multi-viewer” (Picture in Picture, Picture out Picture, Picture and Picture) operation. (see page 18)
 - When MULTI DISPLAY Setup is On (see page 32).
 - When Portrait Setup is On (see page 35).
 - When Screensaver (except for Negative image) is running (see page 28)
- While Digital Zoom is in operation, “Adjusting Pos. / Size” cannot be used.

On-Screen Menu Displays

1 Display the menu screen.

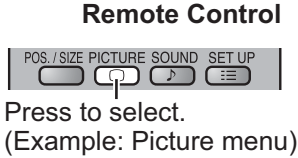

Unit

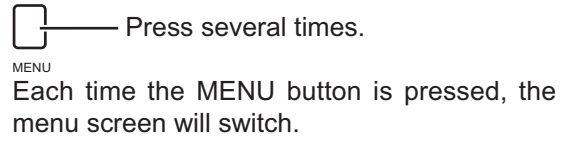

2 Select the item.

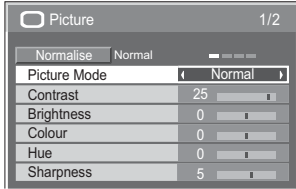

(Example: Picture menu)

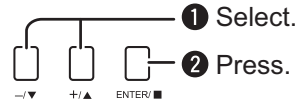
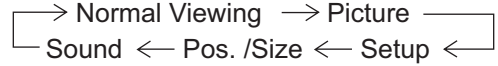
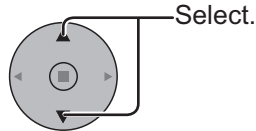

3 Set.

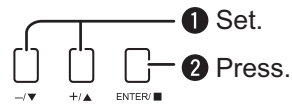
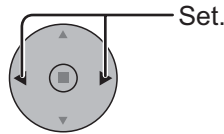

4 Exit the menu.

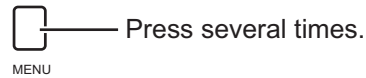
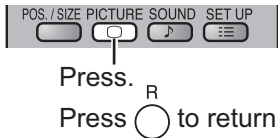

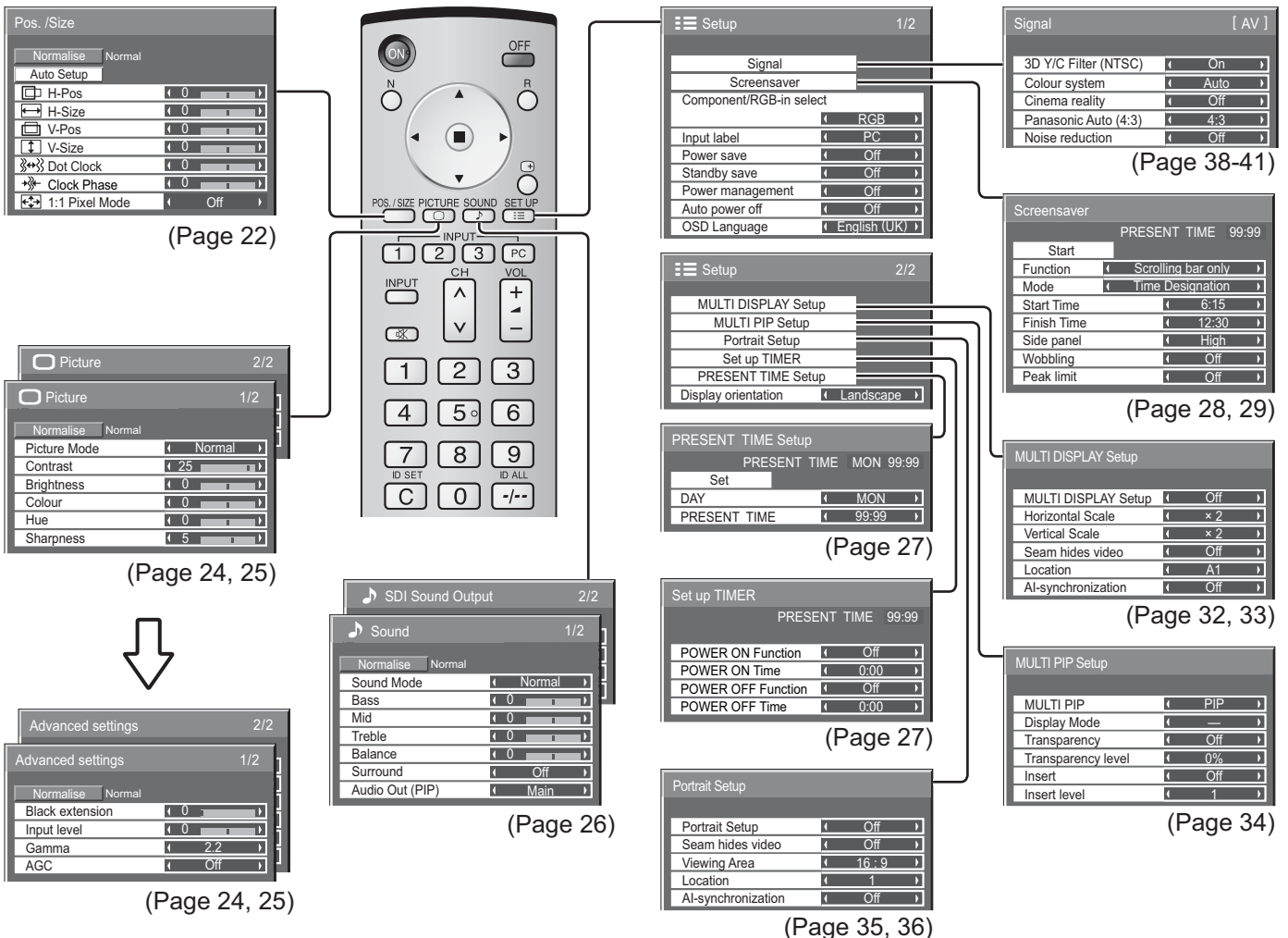

Overview

Note: Menu that cannot be adjusted is grayout. Adjustable menu changes depending on signal, input and menu setting.

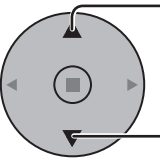
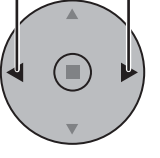

Adjusting Pos. /Size

- 1  Press to display the Pos. /Size menu.
- 2  Press to select the menu to adjust.
- 3  Press to adjust the menu.
- 4  Press to exit from adjust mode.

During "Video (S Video)", "Digital", "SDI" and "HDMI" input signal.

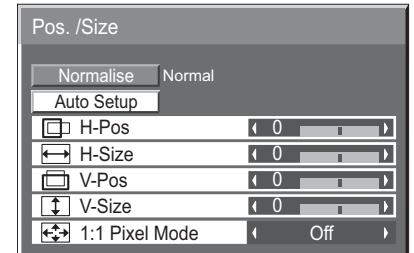

During "Component", "RGB" and "PC" input signal.

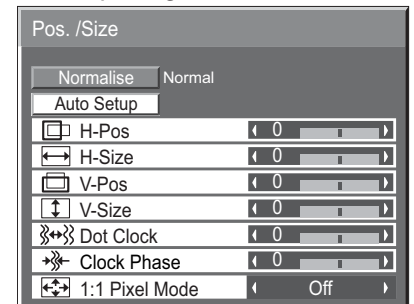

Notes:

- Unadjustable items are grayed out.
- Adjustable items differ depending on the input signal and the display mode.
- Adjustment details are memorized separately for different input signal formats (Adjustments for component signals are memorized for 525 (480) / 60i · 60p, 625 (575) / 50i · 50p, 1125 (1080) / 60i · 50i · 60p · 50p · 24p · 25p · 30p · 24sF, 1250 (1080) / 50i, 750 (720) / 60p · 50p each, and RGB/PC/Digital signals are memorized for each frequency.)
- If a "Cue" or "Rew" signal from a VCR or DVD player is received, the picture position will shift up or down. This picture position movement cannot be controlled by the Picture Pos./Size function.
- If adjusting the Picture V-Pos/V-Size in Panasonic Auto with 16:9 mode, the adjustment is not memorized. When exiting the mode, the screen will return to a former adjustment.

Auto Setup Automatically adjust H-Pos / V-Pos / Clock Phase / Dot Clock and set H-Size / V-Size the standard value when RGB signal is input.

Notes:

- If the dot clock frequency is 162 MHz or higher, Dot Clock cannot be made.
- If the image is that the edge is hardly figured out or shadowy, that cannot be adjusted automatically. In such case, press Auto Setup again after changing the image to the clearer one.
- When DVI-D is input, Clock Phase cannot be adjusted automatically.
- Select Normalise in Pos. /Size and press the ACTION (■) button when appropriate adjustment cannot be made.

H-Pos

Adjust the horizontal position.

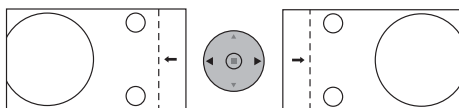

V-Pos

Adjust the vertical position.

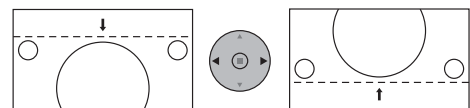

H-Size

Adjust the horizontal size.

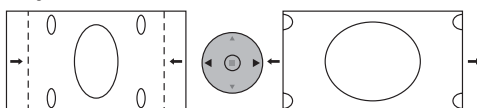

V-Size

Adjust the vertical size.

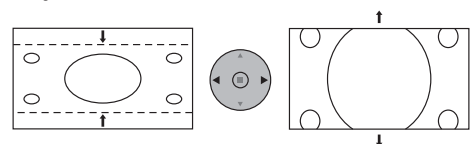

Dot Clock (During "Component", "RGB" and "PC" input signal)

Periodic striped pattern interference (noise) may occur when a striped pattern is displayed. If this happens, adjust so that any such noise is minimized.

Clock Phase (During "Component", "RGB" and "PC" input signal)

Eliminate the flickering and distortion.

1:1 Pixel Mode Adjusts the display size when 1125i, 1125p or 1250i signal is input.

Notes:

- Select On when you would like to replay 1920 × 1080 input signal.
- Applicable input signal;
1125 (1080) / 50i · 60i · 24sF · 24p · 25p · 30p · 50p · 60p, 1250 (1080) / 50i
- Select Off when flickering is shown around the image.
- H-Size, V-Size and Dot Clock cannot be adjusted when On is selected.

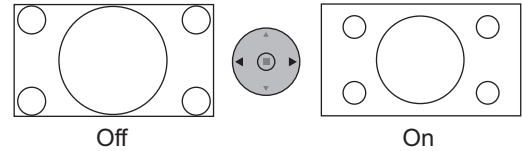

1:1 Pixel Mode (2k1k) When the input signal is a 2k1k signal (2048 × 1080 / 24p, 2048 × 1080 / 24sF), the display size is adjusted as follows.
(For 2k1k signals)

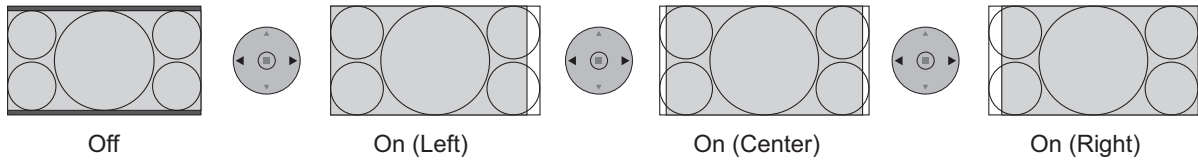

Note:

2k1k signals can only be received when the Dual Link HD-SDI Terminal Board (TY-FB11DHD) is installed.

Helpful Hint (/ **Normalise** **Normalisation**)

While the Pos. /Size display is active, if either the N button on the remote control is pressed at any time or the ACTION () button is pressed during “Normalise”, then all adjustment values are returned to the factory settings.

Picture Adjustments

1 PICTURE  Press to display the Picture menu.

2 Select to adjust each item.

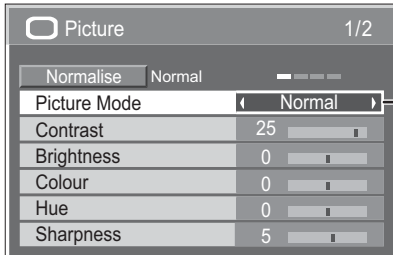
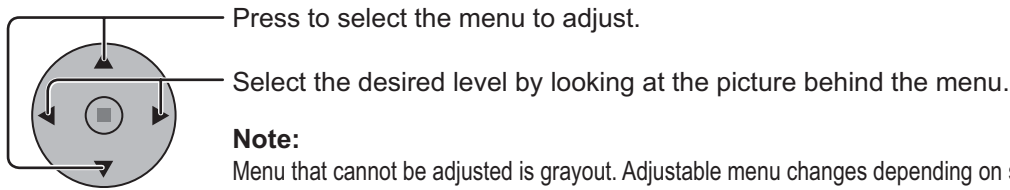

Press “◀” or “▶” button to switch between modes.

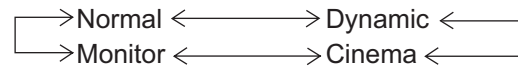

Normal

For viewing in standard (evening lighting) environments. This menu selects the normal levels of Brightness and Contrast.

Dynamic

For viewing in brighter environments. This menu selects higher than normal levels of Brightness and Contrast.

Cinema

Ideal for movies.

Monitor

For use when creating broadcast or movie content. With this picture, even if the overall average picture level (APL) changes, the brightness of areas with the same signal level does not change.

Notes:

- When “Monitor” is selected in Picture Mode, the following menu items cannot be set.
Picture menu: Contrast
Screensaver menu: Peak limit (see page 29)
Setup menu: Power save (see page 30)
MULTI DISPLAY Setup menu: AI-synchronization (see page 33)
Portrait Setup menu: AI-synchronization (see page 36)
- If you would like to change the picture and colour of the selected Picture menu to something else, adjust using the items in the Picture menu. (see next page)

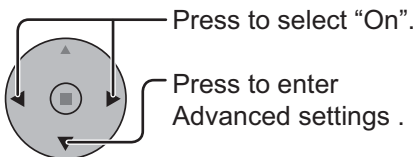
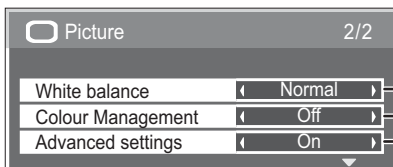

Advanced settings On
Enables fine picture adjustment at a professional level (see next page).

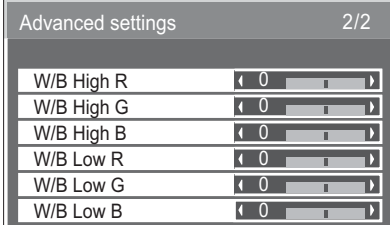
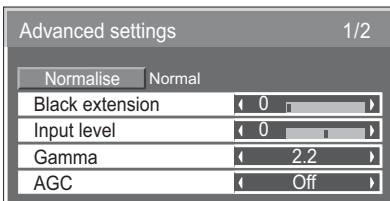

Advanced settings Off
Displays images with settings of the Picture menu.

Press “◀” or “▶” button to switch between modes.



Colour Management On
Enables vivid colour adjustment automatically.

Helpful Hint (/ Normalisation)

While the “Picture” menu is displayed, if either the N button on the remote control is pressed at any time or the ACTION () button is pressed during “Normalise”, then all adjustment values are returned to the factory settings.

Item	Effect	Adjustments
Contrast	Less More	Selects the proper brightness and density for the room.
Brightness	Darker Brighter	Adjusts for easier viewing of dark pictures such as night scenes and black hair.
Colour	Less More	Adjusts colour saturation.
Hue	Reddish Greenish	Adjusts for nice skin colour.
Sharpness	Less More	Adjusts picture sharpness.

Notes:

- “Colour” and “Hue” settings cannot be adjusted for “RGB/PC” and “Digital” input signal.
- You can change the level of each function (Contrast, Brightness, Colour, Hue, Sharpness) for each Picture Mode.
- The setting details for normal, dynamic and cinema respectively are memorized separately for each input terminal.
- The “Hue” setting can be adjusted for NTSC signal only during “AV (S Video)” input signal.
- In Contrast, there is not a noticeable change even when contrast is increased with a bright picture or reduced with a dark picture.

Advanced settings

Item	Effect	Details
Black extension	Less More	Adjusts the dark shades of the image in gradation.
Input level	Less More	Adjustment of parts which are extremely bright and hard to see. (This cannot be adjusted when the input signal is Digital.)
Gamma	Down Up	S Curve \longleftrightarrow 2.0 \longleftrightarrow 2.2 \longleftrightarrow 2.5 \longleftrightarrow 2.6* * When 2k1k signals are received with the Dual Link HD-SDI Terminal Board (TY-FB11DHD), Gamma “2.6” can also be selected.
AGC	Off On	Increases the brightness of dark signal automatically.
W/B High R	Less More	Adjusts the white balance for light red areas.
W/B High G	Less More	Adjusts the white balance for light green areas.
W/B High B	Less More	Adjusts the white balance for light blue areas.
W/B Low R	Less More	Adjusts the white balance for dark red areas.
W/B Low G	Less More	Adjusts the white balance for dark green areas.
W/B Low B	Less More	Adjusts the white balance for dark blue areas.

Notes:

- Carry out “W/B” adjustment as follows.
 1. Adjust the white balance of the bright sections using the “W/B High R”, “W/B High G” and “W/B High B” settings.
 2. Adjust the white balance of the dark sections using the “W/B Low R”, “W/B Low G” and “W/B Low B” settings.
 3. Repeat steps 1 and 2 to adjust.
 Steps 1 and 2 affect each other’s settings, so repeat each step in turn to make the adjustment.
- The adjustment values are memorized separately for each input terminal.
- The adjustment range values should be used as an adjustment reference.

Helpful Hint (/ **Normalise** **Normalisation**)

On the remote control unit, while the “Advanced settings” menu is displayed, if either the N button is pressed at any time or the ACTION () button is pressed during “Normalise”, then all adjustment values are returned to the factory settings.

Sound Adjustment

1  Press to display the Sound menu.

2 Select to adjust each item.

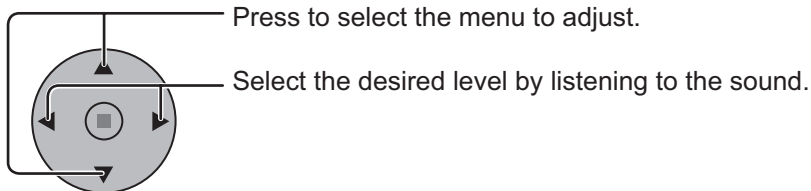

3  Press to exit from adjust mode.

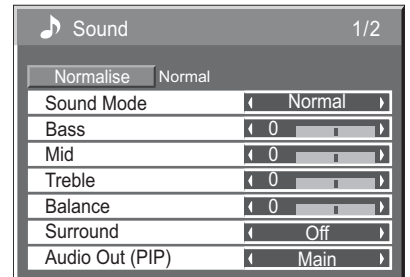

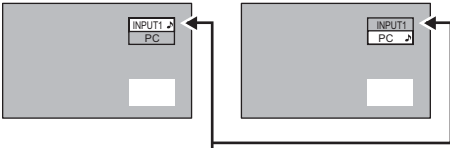
Item	Details
Sound Mode	Normal: Emits the original sound. Dynamic: Accentuates sharp sound. Clear: Attenuates human voice.
Bass	Adjusts low pitch sounds.
Mid	Adjusts normal sounds.
Treble	Adjusts high pitch sounds.
Balance	Adjusts left and right volumes.
Surround	Select On or Off.
Audio Out (PIP)	Main: Selects main picture sound. Sub: Selects PIP frame sound.  Musical note ♪ is displayed on right side of the audio output screen label.

Note: Bass, Mid, Treble and Surround settings are memorized separately for each Sound Mode.

Helpful Hint (/ Normalisation)

While the “Sound” menu is displayed, if either the N button on the remote control is pressed at any time or the ACTION (■) button is pressed during “Normalise”, then all adjustment values are returned to the factory settings.

SDI Sound Output

This menu is displayed when HD-SDI Terminal Board with audio (TY-FB10HD) or Dual Link HD-SDI Terminal Board (TY-FB11DHD) is installed to the unit.

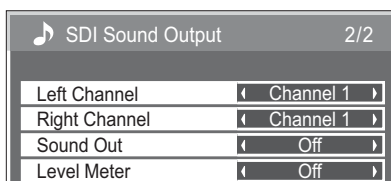

Notes:

- This menu is available only when selecting a slot that HD-SDI Terminal Board with audio (TY-FB10HD) or Dual Link HD-SDI Terminal Board (TY-FB11DHD) is installed.
- This menu is unavailable when two-screen display mode is active.

Item	Details
Left Channel	Channel 1 to Channel 16 Selects left audio channel.
Right Channel	Channel 1 to Channel 16 Selects right audio channel.
Sound Out	On ↔ Off On: Enables audio output. Off: Disables audio output.
Level Meter	Off ↔ 1-8ch ↔ 9-16ch Sets audio channels to show in the audio level meter. 8 channels are displayed in the audio level meter; 4 channels each on both right and left sides of the display. Off: Hides the audio level meter. 1-8ch: Displays the audio level meter (1-8ch) 9-16ch: Displays the audio level meter (9-16ch)

PRESENT TIME Setup / Set up TIMER

The timer can switch the Plasma Display On or Off.

Before attempting Timer Set, confirm the PRESENT TIME and adjust if necessary.
Then set POWER ON Time / POWER OFF Time.

1  Press to display the Setup menu.

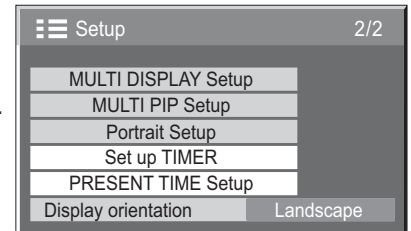

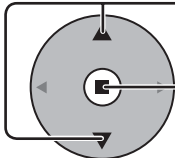
2  Press to select Set up TIMER or PRESENT TIME Setup.
Press to display the Set up TIMER screen or PRESENT TIME Setup screen.

PRESENT TIME Setup

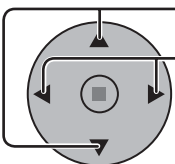
1  Press to select DAY or PRESENT TIME.
Press to setup DAY or PRESENT TIME.
▶ button: Forward
◀ button: Back

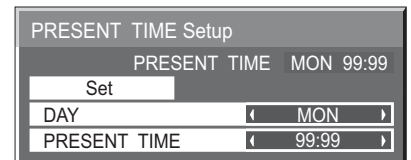

Notes:

- Pressing “◀” or “▶” button once changes PRESENT TIME 1 minute.
- Pressing “◀” or “▶” button continuously changes PRESENT TIME by 15 minutes.

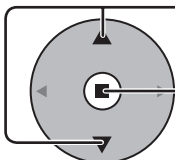
2  Press to select Set.
Press to store PRESENT TIME Setup.

Notes:

- Set cannot be selected unless PRESENT TIME is set.
- Unless setting the present time other than “99:99”, DAY setting is invalid.
- The settings of “DAY” and “PRESENT TIME” are reset when leaving the display turned off for about 7 days for the following reasons:
Pressing ⏻/| switch of the unit to turn off the display.
Disconnecting the AC cord.
Interruption of power supply.

Set up TIMER

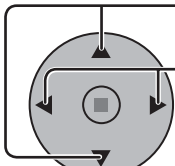
1  Press to select POWER ON Time / POWER OFF Time.
Press to setup POWER ON Time / POWER OFF Time.
▶ button: Forward
◀ button: Back

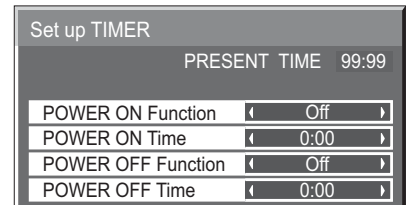

Notes:

- Pressing “◀” or “▶” button once changes POWER ON Time / POWER OFF Time 1 minute.
- Pressing “◀” or “▶” button continuously changes POWER ON Time / POWER OFF Time by 15 minutes.

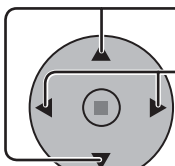
2  Press to select POWER ON Function/POWER OFF Function.
Press to select On.

Note: Timer function will not work unless “PRESENT TIME” is set.

Screensaver (For preventing image retention)

Do not display a still picture, especially in 4:3 mode, for any length of time.
If the display must remain on, a Screensaver should be used.

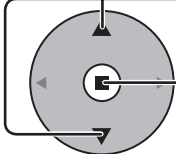
- 1  Press to display the Setup menu.
- 2  Press to select Screensaver.
Press to display Screensaver screen.

3 Function selection

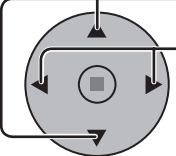
- 3  Press to select Function.
Press to select the desired function.
- > Negative image <-> Scrolling bar only <->
 > White screen <-> Overlay scrolling bar <->

Negative image : Negative image will be displayed on the screen.

Scrolling bar only : A white bar will scroll from left to right. The image won't be displayed.

Overlay scrolling bar : The brightness of the image will be decreased and a white bar will scroll on it.

White screen : The whole screen will be white.

Note: Overlay scrolling bar is not effective during two screen display.

4 Mode selection

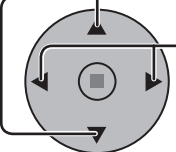
- 4  Press to select Mode.
Press to select each mode items.

- Off
- Interval : Operates when Periodic Time and Operating Time are setup and those times arrive.
- Time Designation : Operates when Start Time and Finish Time are setup and those times arrive.
- On : Operates when Start is selected and the ACTION (■) button is pressed.

5 Start setting

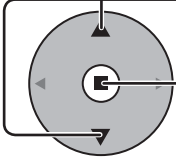
- 5  When the Mode is set to On, press to select Start.
Press to start Screensaver.
The menu screen will disappear and the Screensaver will be activated. **To stop the Screensaver under On, press the R button or any buttons on the main unit.**



Note: When the display is turned off, the Screensaver will be deactivated.

Setup		1/2
Signal		
Screensaver		
Component/RGB-in select		
	RGB	
Input label	PC	
Power save	Off	
Standby save	Off	
Power management	Off	
Auto power off	Off	
OSD Language	English (UK)	

Screensaver		PRESENT TIME 99:99
Start		
Function	Scrolling bar only	
Mode	Off	
Start Time	6:15	
Finish Time	12:30	
Side panel	High	
Wobbling	Off	
Peak limit	Off	

Setup of Screensaver Time

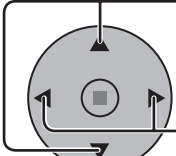
After selecting Time Designation or Interval, the relevant Time Setup will become available for selection and the Operating Time may be set. (Time cannot be set when "Mode" is "On" or "Off".)

- 1  Press to select Start Time / Finish Time (When Time Designation is selected).
Press to select Periodic Time / Operating Time (When Interval is selected).
- 2  Press to setup.
▶ button: Forward
◀ button: Back

Screensaver		PRESENT TIME 15:00
Start		
Function	Scrolling bar only	
Mode	Time Designation	
Start Time	6:15	
Finish Time	12:30	

Screensaver		PRESENT TIME 15:00
Start		
Function	Scrolling bar only	
Mode	Interval	
Periodic Time	12:00	
Operating Time	3:00	

Notes:

- Pressing "◀" or "▶" button once changes the Time 1 minute.
[However, switching occurs every 15 minutes when Periodic Time is selected.]
- Pressing "◀" or "▶" button continuously changes the Time by 15 minutes.

Note: Timer function will not work unless "PRESENT TIME" is set.

Reduces screen image retention

These functions prevent the occurrence of an "image retention" on the display when turned ON.

Wobbling: Automatically shifts the display image (therefore unnoticeable to the eye) to prevent image retention of sharper contour of image.

On1: Shifts the image every 30 seconds.

On2: Shifts the image at a dot level pitch depending on screen-detection.

Peak limit: Suppresses image contrast (peak brightness).

Note: When a still picture is viewed for an extended time, the screen may become slightly darker. (see page 47)

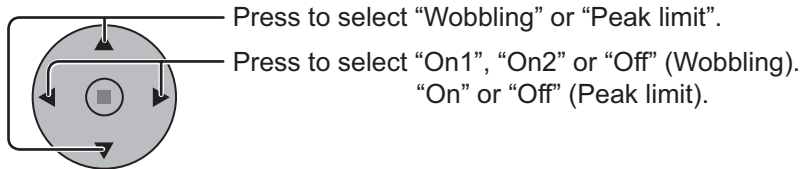

Screensaver	
PRESENT TIME	99:99
Start	
Function	Scrolling bar only
Mode	Off
Start Time	6:15
Finish Time	12:30
Side panel	High
Wobbling	Off
Peak limit	Off

Side Panel Adjustment

Do not display a picture in 4:3 mode for an extended period, as this can cause an image retention to remain on the side panels either side of the display field.

To reduce the risk of such an image retention, illuminate the side panels.

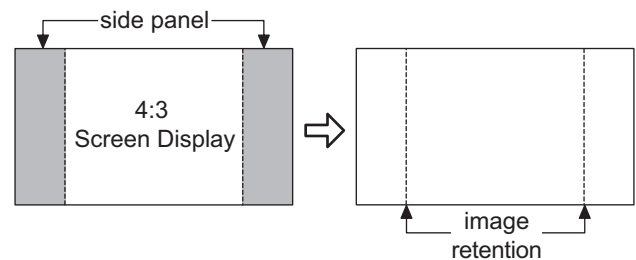

This function may be applicable to the non-picture area.

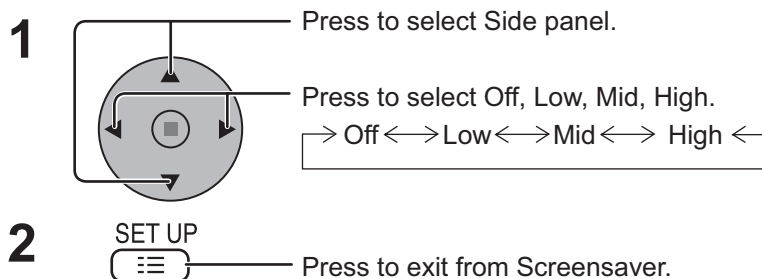
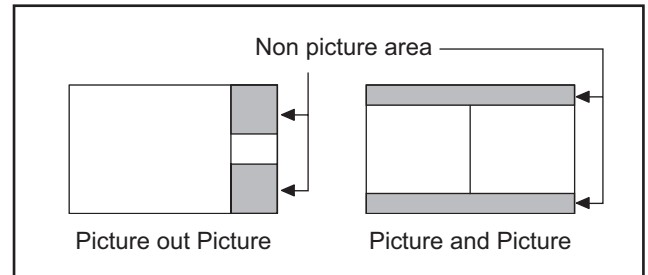

Screensaver	
PRESENT TIME	99:99
Start	----
Function	Scrolling bar only
Mode	Off
Start Time	6:15
Finish Time	12:30
Side panel	High
Wobbling	Off
Peak limit	Off

Notes:

- To reduce the occurrence of image retention, set the Side panel to High.
- The side panels may flash (alternate black / white) depending on the picture being shown on the screen. Using Cinema mode will reduce such flashing.

Reduces power consumption

- **Power save:** When this function is turned On, luminous level of the Plasma Display is suppressed, so power consumption is reduced.
 - **Standby save:** When this function is turned On, power consumption of the microcomputer is reduced during power supply standby (see page 12, 15, 16), so standby power of the set is reduced.
 - **Power management:** When this function is set to On, it operates under the following conditions to turn the power on or off automatically.
When no pictures (HD/VD sync signals) are detected for 30 or so seconds during PC IN signal input:
→ Power is turned off (standby); the power indicator lights up orange.
When pictures (HD/VD sync signals) are subsequently detected:
→ Power is turned on; the power indicator lights up green.
- Notes:**
- This function operates only during PC IN signal input.
 - This function is invalid during input from PC Input Terminal Board (TY-42TM6P).
 - This function is effective when "Sync" is set to "Auto", "Component / RGB-in select" is set to "RGB" and during normal viewing (one picture screen).
- **Auto power off:** Equipment power supply is turned Off when there is no signal.
When this is set to On, the power supply of the unit goes Off 10 minutes after the input signals stop.
- Note:**
This function is effective during normal viewing (one picture screen) for input signals except PC IN terminal.

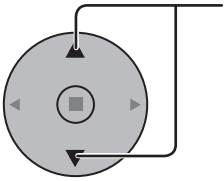
- 

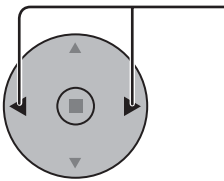
Press to select
"Power save"
"Standby save"
"Power management"
"Auto power off".
- 

Press to select "On" or "Off".
On ← → Off
- 

SET UP
Press to exit from Setup.

Setup 1/2	
Signal	
Screensaver	
Component/RGB-in select	
	RGB
Input label	PC
Power save	Off
Standby save	Off
Power management	Off
Auto power off	Off
OSD Language	English (UK)

Customizing the Input labels

This function can change the label of the Input signal to be displayed. Select the input signal which you would like to change its label before customizing the Input labels. (see page 14, 16)

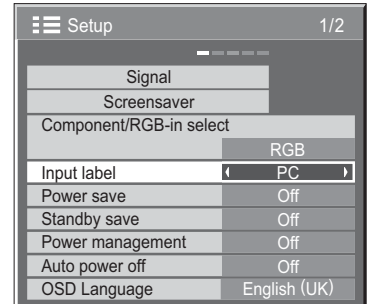
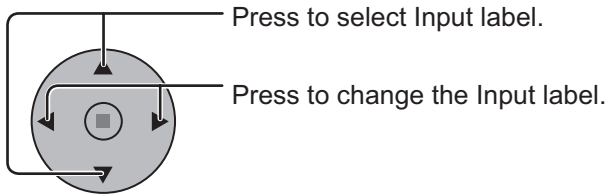

Note:

While selecting an Input signal through Optional Terminal Board connected to Slot1, Slot2 and Slot3, the Input label will depend on each Optional Terminal Board.

Input labels for Slot1, Slot2, Slot3 and Mini D-sub:

- [Slot1 Input] INPUT1 / VIDEO1 / COMPONENT1 / RGB1 / DIGITAL1 / PC1 / DVD1 / CATV1 / VCR1 / STB1
- [Slot2 Input] INPUT2 / VIDEO2 / COMPONENT2 / RGB2 / DIGITAL2 / PC2 / DVD2 / CATV2 / VCR2 / STB2
- [Slot3 Input] INPUT3 / VIDEO3 / COMPONENT3 / RGB3 / PC3 / DVD3 / CATV3 / VCR3 / STB3
- [PC (Mini D-sub) input] PC / COMPONENT / RGB / DVD / STB

When BNC Dual Video Terminal Board (TY-FB9BD) is used, an "A" or "B" is added at the end of each input label, depending on the input selected (see below).

Addition sign	"A"	"B"
Selected Input	Composite	S VIDEO

Display orientation

Sets the fan control and the display style of on-screen menu for vertical installation.

- 1 Press to display the Setup menu.
- 2 Press to select Display orientation.
Press to select "Landscape" or "Portrait".
- 3 Press to exit from adjust mode

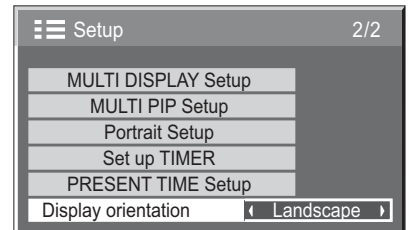

Landscape

Fan control for horizontal installation.

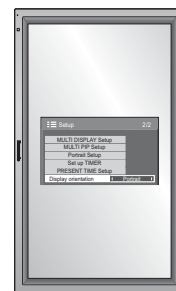

Portrait

Fan control for vertical installation. On-screen menu will be rotated 90 degrees counterclockwise to be suitable for the setting.

Notes:

- Turn up the power switch for the upward direction when you set Display vertically.
- Fan control will be switched when turning on the unit next time.

Setup for MULTI DISPLAY

By lining up Plasma Displays in groups, for example, as illustrated below, an enlarged picture may be displayed across all screens.

For this mode of operation, each plasma display has to be set up with a Display number to determine its location.

(Example)

group of 4 (2 × 2)



group of 9 (3 × 3)



group of 16 (4 × 4)





group of 25 (5 × 5)

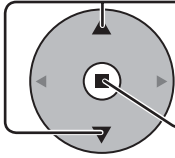
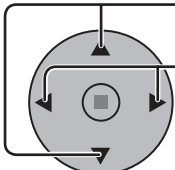

How to Setup MULTI DISPLAY

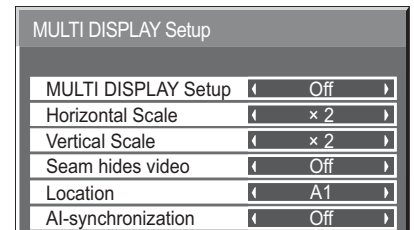
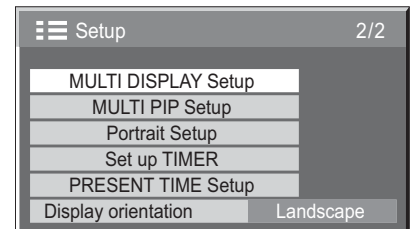
- 1 **SET UP**
 Press to display the Setup menu.
- 2 
 Press to select the MULTI DISPLAY Setup.
 Press to display the "MULTI DISPLAY Setup" menu.
- 3 
 Press to select the menu to adjust.
 Press to adjust the menu.





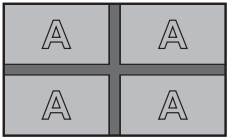





Item	Details																																																									
MULTI DISPLAY Setup	Select "On" or "Off". Note: If you set MULTI DISPLAY Setup to On, Portrait Setup will be unavailable.																																																									
Horizontal Scale	Select "× 1", "× 2", "× 3", "× 4", "× 5".																																																									
Vertical Scale	Select "× 1", "× 2", "× 3", "× 4", "× 5".																																																									
Seam hides video	Select "On" or "Off". <div style="display: flex; justify-content: space-around; align-items: flex-start;"> <div style="text-align: center;"> <p>To hide joints between displays.</p>  <p>Example</p> <p>Suitable for moving image display.</p> <p>On</p> </div> <div style="text-align: center;"> <p>To show joints between displays.</p>  <p>Example</p> <p>Suitable for still image display.</p> <p>Off</p> </div> </div>																																																									
Location	Select the required arrangement number. (A1-E5 : Refer to the following) Display Number locations for each arrangement. (Examples) <div style="display: flex; justify-content: space-around; align-items: flex-start;"> <div style="text-align: center;"> <p>(2 × 1)</p> <table border="1" style="border-collapse: collapse;"> <tr><td>A1</td><td>A2</td></tr> </table> </div> <div style="text-align: center;"> <p>(2 × 3)</p> <table border="1" style="border-collapse: collapse;"> <tr><td>A1</td><td>A2</td></tr> <tr><td>B1</td><td>B2</td></tr> <tr><td>C1</td><td>C2</td></tr> </table> </div> <div style="text-align: center;"> <p>(4 × 2)</p> <table border="1" style="border-collapse: collapse;"> <tr><td>A1</td><td>A2</td><td>A3</td><td>A4</td></tr> <tr><td>B1</td><td>B2</td><td>B3</td><td>B4</td></tr> </table> </div> <div style="text-align: center;"> <p>(4 × 4)</p> <table border="1" style="border-collapse: collapse;"> <tr><td>A1</td><td>A2</td><td>A3</td><td>A4</td></tr> <tr><td>B1</td><td>B2</td><td>B3</td><td>B4</td></tr> <tr><td>C1</td><td>C2</td><td>C3</td><td>C4</td></tr> <tr><td>D1</td><td>D2</td><td>D3</td><td>D4</td></tr> </table> </div> <div style="text-align: center;"> <p>(5 × 5)</p> <table border="1" style="border-collapse: collapse;"> <tr><td>A1</td><td>A2</td><td>A3</td><td>A4</td><td>A5</td></tr> <tr><td>B1</td><td>B2</td><td>B3</td><td>B4</td><td>B5</td></tr> <tr><td>C1</td><td>C2</td><td>C3</td><td>C4</td><td>C5</td></tr> <tr><td>D1</td><td>D2</td><td>D3</td><td>D4</td><td>D5</td></tr> <tr><td>E1</td><td>E2</td><td>E3</td><td>E4</td><td>E5</td></tr> </table> </div> </div>	A1	A2	A1	A2	B1	B2	C1	C2	A1	A2	A3	A4	B1	B2	B3	B4	A1	A2	A3	A4	B1	B2	B3	B4	C1	C2	C3	C4	D1	D2	D3	D4	A1	A2	A3	A4	A5	B1	B2	B3	B4	B5	C1	C2	C3	C4	C5	D1	D2	D3	D4	D5	E1	E2	E3	E4	E5
A1	A2																																																									
A1	A2																																																									
B1	B2																																																									
C1	C2																																																									
A1	A2	A3	A4																																																							
B1	B2	B3	B4																																																							
A1	A2	A3	A4																																																							
B1	B2	B3	B4																																																							
C1	C2	C3	C4																																																							
D1	D2	D3	D4																																																							
A1	A2	A3	A4	A5																																																						
B1	B2	B3	B4	B5																																																						
C1	C2	C3	C4	C5																																																						
D1	D2	D3	D4	D5																																																						
E1	E2	E3	E4	E5																																																						

Item	Details
AI-Synchronization	<p>Select "Off" or "On".</p> <p>The brightness depends on each display's setting.</p>  <p>Off</p> <p>Equalize the brightness of all the displays.</p>  <p>On</p> <p>Note: If you set AI-synchronization to On, the following menus will be unavailable and these settings will be fixed to the initial values. Picture menu: Colour, Hue, Input level (Advanced settings)</p>

- 4**  Press twice to exit from Setup.

ID Remote Control Function

You can set the remote control ID when you want to use this remote control on one of several different displays.

- 1** Switch  to  on the right side.
- 2** Press the  button on the remote control.
- 3** Press one of  - ,  for the tens digit setting.
- 4** Press one of  - ,  for the units digit setting.

Notes:

- The numbers in 2, 3 and 4 should be set up quickly.
- Adjustable ID number range is 0 - 99.
- If a number button is pressed more than two times, the first two numbers become the ID number for the remote control.

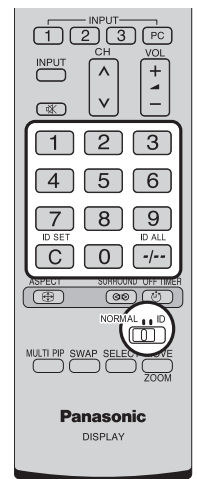

ID remote control button operation

The operation is the same as normal remote control except for the  button.

ID Cancellation



Press  button on remote control. (This has the same effect as pressing the , ,  buttons at the same time.)

Notes:

- Set the Remote ID "On" to operate the ID remote control.
If remote ID is set to "On", you can use the remote control without identical ID number during option menu display. (see page 43)
- The ID remote control cannot be used when ID select is set to anything other than 0, and the remote control ID is not the same as the ID select number (see page 43).

MULTI PIP Setup

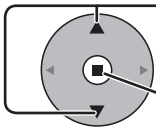
Set the two-screen display function that is activated when  is pressed.

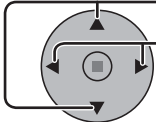
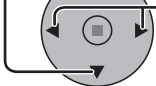
- 1  Press to display the Setup menu.
- 2  Press to select the MULTI PIP Setup.
 Press to display the "MULTI PIP Setup" menu.
- 3  Press to select the menu to adjust.
 Press to adjust the menu.

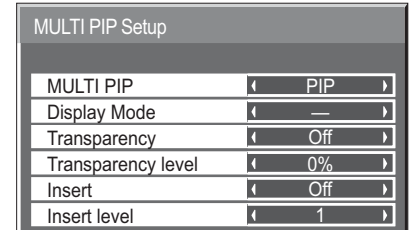
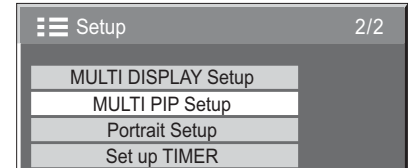

MULTI PIP

Set the two-screen function.

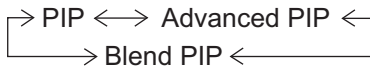



Display Mode

The display mode can be changed separately for each function that was set in "MULTI PIP Setup".

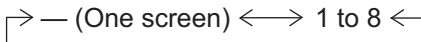
For "PIP": 

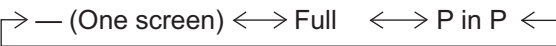
For "Advanced PIP": 

For "Blend PIP": 

Note: The display mode changes in the same way when  is pressed.

Transparent Display of the Sub Screen (During Blend PIP)

- ① Select "On" in "Transparency".
- ② Set the transparency level for the sub screen in "Transparency level". (0 to 100 %)
 Setting example Transparent image (sub screen)



Note: "Insert" cannot be set when "Transparency" is "On".

Sub Screen Insertion (During BLEND PIP)

- ① Select "On" in "Insert".
- ② Set the "Insert level". (1 to 10 %)
 Set the brightness level threshold for discriminating between the transparent areas and non-transparent areas on the sub screen.

Setting example Image to insert (sub screen)

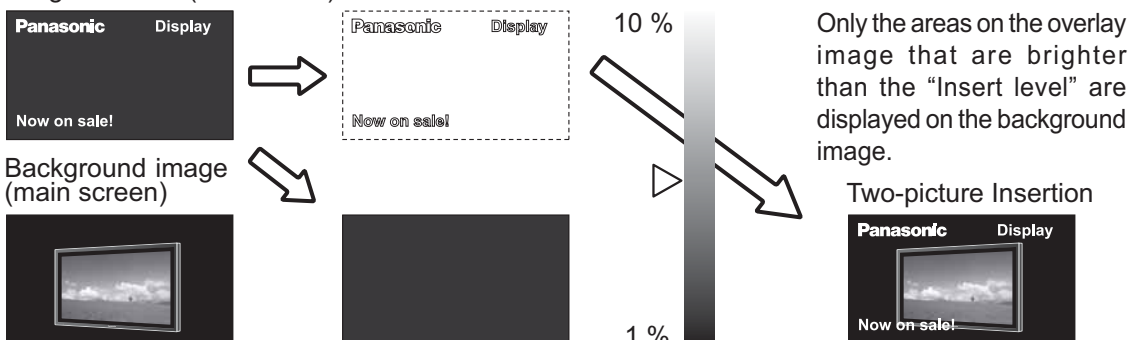

Note: "Transparency" cannot be set when "Insert" is "On".

Set up for Portrait

Divide an input image into 3 parts, and display one of them to a plasma display which is set vertically. The image will be enlarged 3 times and rotated 90-degree.

(Example)

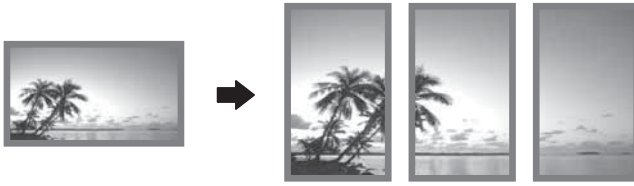

Note:

When using the Portrait function with displays set vertically, "Display orientation" in Setup menu has to be set to "Portrait" (see page 31).

How to setup Portrait

1 Press to display the Setup menu.

2 Press to select the Portrait Setup.
 Press to display the "Portrait Setup" menu.

3 Press to select the Portrait Setup.
 Press to select "On" or "Off".

Note:
If you set Portrait Setup to On, MULTI DISPLAY Setup will be unavailable.

4 Press to select Seam hides video.
 Press to select "Off", "On".

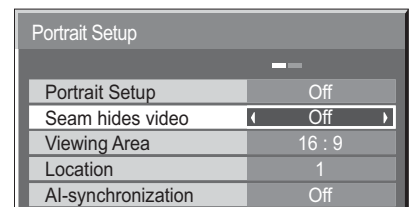
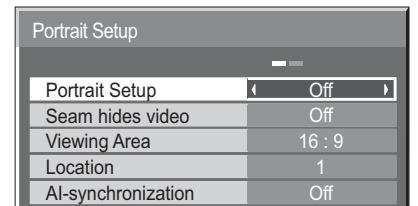
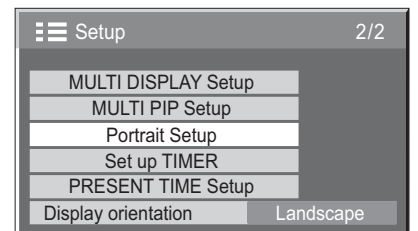
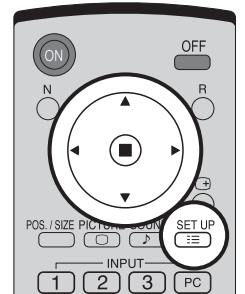

<p>To hide joints between displays.</p> <p>Example</p> <p>Suitable for moving image display.</p> <p>On</p>	<p>To show joints between displays.</p> <p>Example</p> <p>Suitable for still image display.</p> <p>Off</p>
---	---

5 Viewing Area / Location

Viewing Area: Set a mode of image division for Portrait function.

Location: Set a location of image to be displayed for Portrait function.

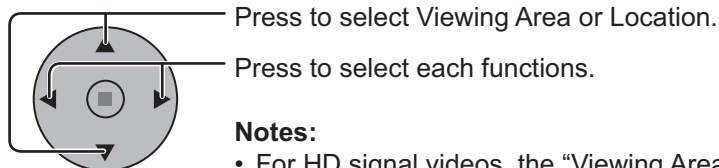

Notes:

- For HD signal videos, the "Viewing Area" is set at "16:9", and cannot be changed.
HD signal: 1125(1080) / 60i • 50i • 60p • 50p • 24p • 25p • 30p • 24sF, 750(720) / 60p • 50p, 1250(1080) / 50i
- When "Viewing Area" is "16:9", the aspect mode is set to "16:9".

Portrait Setup	
Portrait Setup	Off
Seam hides video	Off
Viewing Area	16 : 9
Location	1
AI-synchronization	Off

Location setting

When Portrait Setup is "On":

Display the image of the selected location.



When Portrait Setup is "Off":

Represent an area of the selected Location at a normal brightness and darken the rest of it.

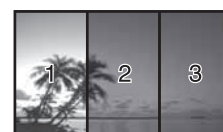

Viewing Area and Location

The mode of image division and the Location by setting of Viewing Area is as follows.

Viewing Area : 16:9

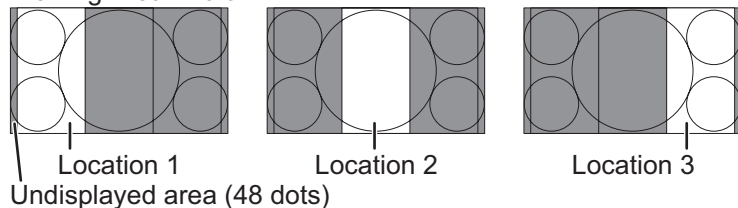

Suitable to display 16:9 images. 4:3 images extend transversely. Both right and left sides of the image are cut by 48 dots.

Viewing Area : 4:3

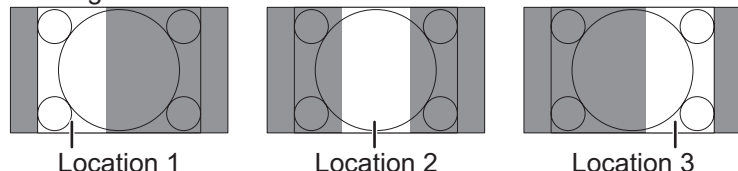

4:3 images are displayed without changing aspect ratio. Although the images of each Location overlap, you can adjust Pos. / Size to display the image normally. (see page 22)

6 AI-synchronization

Adjust to equalize the brightness of the 3 displays when using Portrait setting.

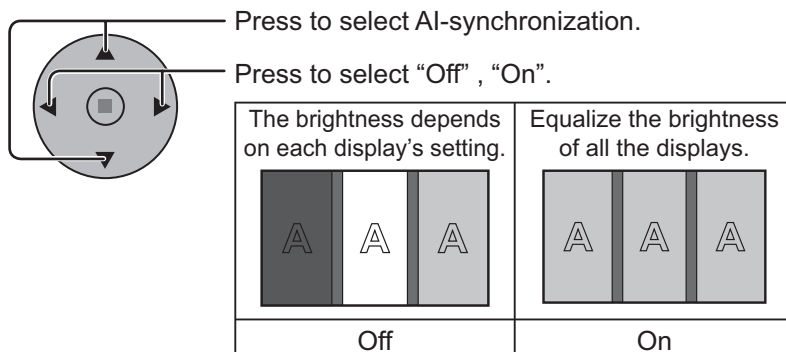

Portrait Setup	
Portrait Setup	Off
Seam hides video	Off
Viewing Area	16 : 9
Location	1
AI-synchronization	Off

Note:

If you set AI-synchronization to On, the following menus will be unavailable and these settings will be fixed to the initial values.

Picture menu: Colour, Hue, Input level (Advanced settings)

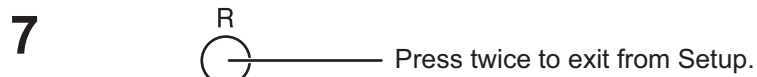



Setup for Input Signals

Component / RGB-in select

Select to match the signals from the source connected to the Component / RGB input terminals.

Y, P_B, P_R signals ⇔ "Component"

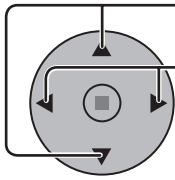
RGB signals ⇔ "RGB"

-  Press to display the Setup menu.
-  Press to select the "Component / RGB-in select".
Press to select the desired input signal.
Component ← → RGB
-  Press to exit from adjust mode.

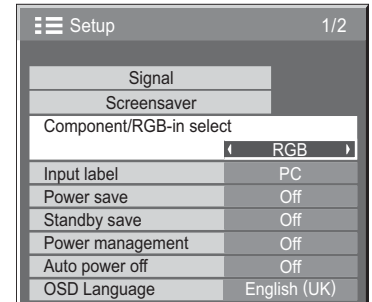

Notes:



- Selection may not be possible, depending on which optional board is installed.
- Make setting of the selected input terminal (SLOT1, SLOT2, SLOT3 or PC IN).

YUV / RGB-in select

Select to match the signals from the source connected to the DVI input terminals.

YUV signals ⇔ "YUV"

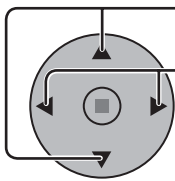
RGB signals ⇔ "RGB"

-  Press to display the Setup menu.
-  Press to select the "YUV / RGB-in select".
Press to select the desired mode.
YUV ← → RGB
-  Press to exit from adjust mode.

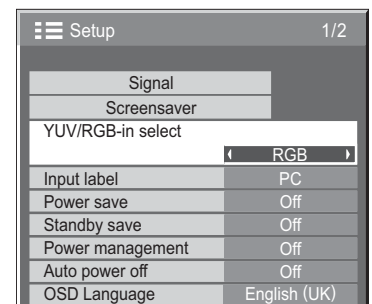



Notes:

- Selection may not be possible, depending on which optional board is installed.
- Make setting of the selected input terminal (SLOT1 or SLOT2).

Signal menu

Note:

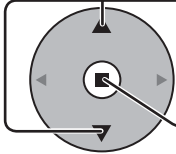
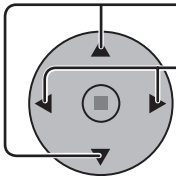
“Signal” setup menu displays a different setting condition for each input signal.

- 1  Press to display the Setup menu.
- 2  Press to select the “Signal”.
Press to display the Signal menu.
- 3  Press to select the menu to adjust.
Press to adjust the menu.
- 4  Press to exit from adjust mode.

Setup 1/2	
Signal	
Screensaver	
Component/RGB-in select	RGB
Input label	PC
Power save	Off
Standby save	Off
Power management	Off
Auto power off	Off
OSD Language	English (UK)

Press ACTION (■) button

For Video (S VIDEO)

Signal [AV]	
3D Y/C Filter (NTSC)	On
Colour system	Auto
Cinema reality	Off
Panasonic Auto (4:3)	4:3
Noise reduction	Off

For RGB

Signal [RGB]	
Sync	Auto
Cinema reality	Off
XGA Mode	1024 × 768
Noise reduction	Off
H-Freq.	63.98 kHz
V-Freq.	60.02 Hz
Signal Format	1280×1024/60

For Component

Signal [Component]	
Cinema reality	Off
XGA Mode	1024 × 768
Noise reduction	Off
H-Freq.	63.98 kHz
V-Freq.	60.02 Hz
Signal Format	1280×1024/60

For Digital

Signal [Digital]	
Cinema reality	Off
Noise reduction	Off
H-Freq.	63.98 kHz
V-Freq.	60.02 Hz
Dot Clock Freq.	108.0 MHz
Signal Format	1280×1024/60

3D Y/C Filter – For NTSC AV images

Select “Signal” from the “Setup” menu during AV(S Video) input signal. (“Signal [AV]” menu is displayed.)

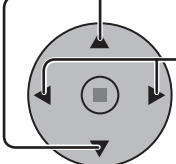
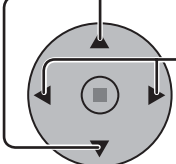
- 1  Press to select the “3D Y/C Filter (NTSC)”
- 2  Press to set On / Off.

3D Y/C Filter (NTSC)	On
----------------------	----

Note:

When On, this setting only affects NTSC input signals.

Colour system / Panasonic Auto

Select Signal from the “Setup” menu during AV(S Video) input signal. (“Signal [AV]” menu is displayed.)

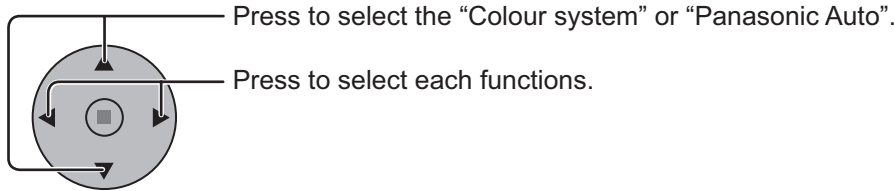

Signal [AV]	
3D Y/C Filter (NTSC)	On
Colour system	Auto
Cinema reality	Off
Panasonic Auto (4 : 3)	4 : 3
Noise reduction	Off

If the picture image becomes unstable:

With the system set on Auto, under conditions of low level or noisy input signals the image may in rare cases become unstable. Should this occur, set the system to match the format of the input signal.

Mode	Function
Colour system	Set the colour system to match the input signal. When selecting “Auto”, the colour system is automatically selected from NTSC/PAL/SECAM, however, M.NTSC signal is not displayed properly depending on the attached terminal board. To display M.NTSC signal, select “M.NTSC” in Colour system. <div style="text-align: center;"> → Auto ← → PAL ← → SECAM ← → M.NTSC ← → NTSC ← </div>
Panasonic Auto (4 : 3)	Set to “4 : 3” to view 4:3 images in an unchanged format when Panasonic Auto is selected. If you would like to view 4:3 images in Just format, set to “Just”.

Note:

Panasonic Auto does not function when BNC Dual Video Terminal Board (TY-FB9BD) is used.

Cinema reality

Cinema reality:

When on, the display attempts to reproduce a more natural interpretation of sources such as movie pictures, which are recorded at 24 frames per second. If the picture is not stable, turn the setting to off.

Note:

When On, this setting only affects the following signal input:

- NTSC / PAL signal input during “AV(S Video)” input signal.
- 525i(480i), 625i(575i), 1125(1080) / 60i signal input during “Component” input signal.

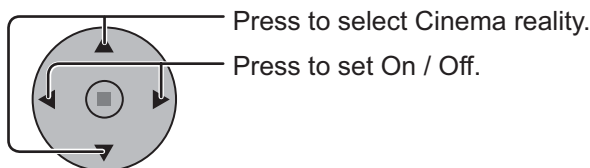

Cinema reality	Off
----------------	-----

XGA Mode

This menu is displayed when the input signal is analog (Component/PC). This unit supports three types of XGA signals with 60Hz vertical frequency having different aspect ratios and sampling rates (1,024 × 768 @ 60Hz, 1,280 × 768 @ 60Hz, and 1,366 × 768 @ 60Hz). Be sure to make settings in accordance with the input signal in order to achieve a more appropriate and attractive display.

In addition, after making this setting, be sure to make each adjustment (such as “Auto Setup”) on the “Pos. /Size” menu as necessary. (see page 22)

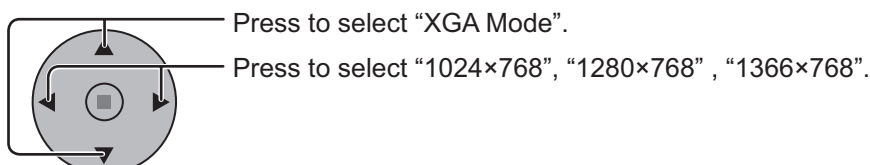

XGA Mode	1024 × 768
----------	------------

Noise reduction

Sets the following three NR (Noise Reduction) functions together.
P-NR, Mosquito NR, Block NR

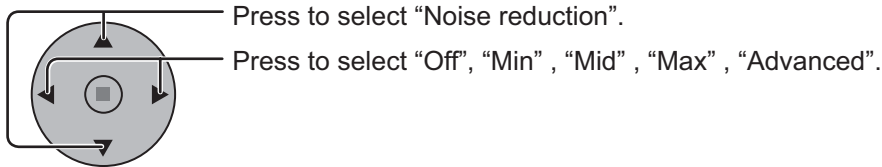

Advanced NR

Sets the three NR functions separately.

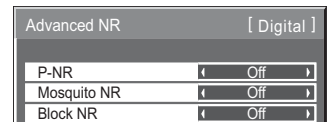
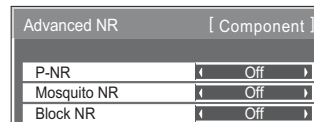
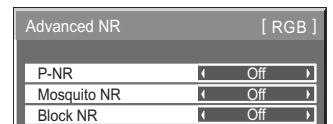
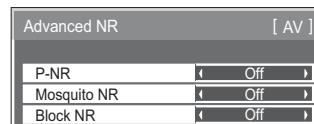
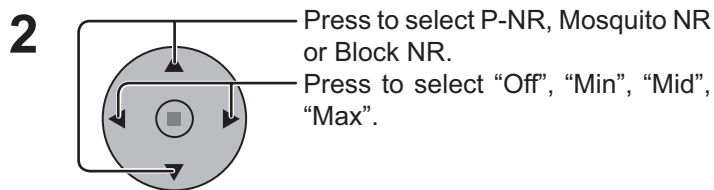
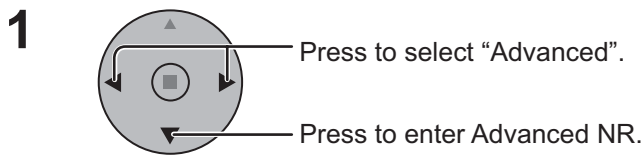

P-NR: Automatically reduces unwanted picture noise.

Mosquito NR: Reduces mosquito noise around subtitles on MPEG videos.

Block NR: Reduces block noise when playing MPEG videos.

Notes:

- Noise reduction cannot be adjusted while a PC signal is being applied.
- Block NR cannot be adjusted while a HD signal is being applied.

Sync

Select Signal from the “Setup” menu during RGB input signal.

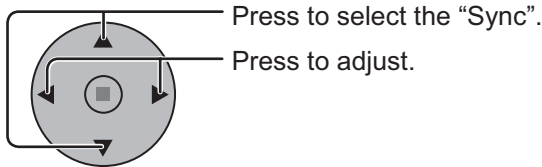

Signal [RGB]	
Sync	Auto
Cinema reality	Off
XGA Mode	1024 × 768

Setting RGB sync signal:

Confirm that the input is set to RGB input (this setting is valid only for RGB input signal).

- Auto: The H and V sync or synchronized signal are automatically selected. If both input, it is selected the H and V sync.
- on G: Uses a synchronized signal on the Video G signal, which is input from the G connector.
- VBS: Uses a synchronized signal of Composite Sync input, which is input from the HD connector.

Sync	Auto
↑ ↓	
Sync	on G
↑ ↓	
Sync	VBS

SDI Through

Set the active through function of the Dual Link HD-SDI Terminal Board (TY-FB11DHD).

Note:

Settings can only be performed for this menu when a slot mounted with a Dual Link HD-SDI Terminal Board (TY-FB11DHD) is selected.

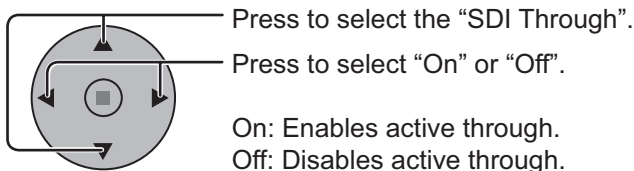

Signal [Digital]	
Cinema reality	Off
SDI Through	Off
Noise reduction	Off

Input signal display

Displays the frequency and the type of the current input signal.

This display is valid only for Component / RGB / PC and Digital input signal.

Display range:





- Horizontal 15 - 110 kHz
- Vertical 48 - 120 Hz

The dot clock frequency is displayed during digital signal input.

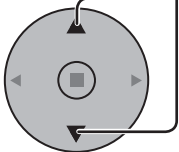

H-Freq.	63.98	kHz
V-Freq.	60.02	Hz
Signal Format	1280×1024/60	

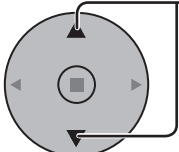
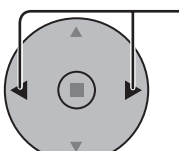
H-Freq.	63.98	kHz
V-Freq.	60.02	Hz
Dot Clock Freq.	108.0	MHz
Signal Format	1280×1024/60	

Options Adjustments

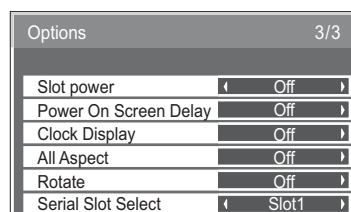
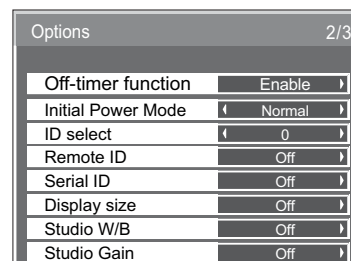
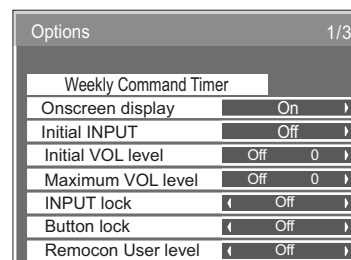
- 1  Press to display the Setup menu.
- 2  Press to select "OSD Language".
- 3  Press and hold until the Options menu is displayed.
- 4  Press to select your preferred menu.
- 5  Press to adjust the menu.
- 6  Press to exit from Options menu.



Item	Adjustments
Weekly Command Timer	Sets Weekly Command Timer. (see page 45)
Onscreen display	<p>On: Displays all the following on screen.</p> <ul style="list-style-type: none"> • Power on display • Input signal switch display • No signal display • Mute and the remaining time of off-timer after  was pressed. <p>Off: Hides all the items above from view.</p>
Initial INPUT	<p>Off <=> PC <=> INPUT1 <=> INPUT2 <=> INPUT3 Adjusts the input signal when the unit is turned on.</p> <p>Notes:</p> <ul style="list-style-type: none"> • Only the adjusted signal is displayed. (see page 14) • Signal can be displayed when the Terminal board is installed. • This menu is available only when "INPUT lock" is "Off". • When a dual input terminal board is attached, A or B is displayed depending on the selected input signal. (Ex. INPUT1A, INPUT1B)
Initial VOL level	<p>Press  button to adjust the volume when the unit is turned on.</p> <p>Off <=> On</p> <p>Off: Sets normal volume.</p> <p>On: Sets your preferred volume.</p> <p>Notes:</p> <ul style="list-style-type: none"> • When "Maximum VOL level" is "On", the volume can only be adjusted between 0 and your maximum range. • You can hear the changed volume regardless of your volume setting before opening the options menu if you adjust the volume when "Initial VOL level" is "On" and cursor is on the menu.
Maximum VOL level	<p>Press  button to adjust the maximum volume.</p> <p>Off <=> On</p> <p>Off: Sets auto maximum volume.</p> <p>On: Sets your preferred maximum volume.</p> <p>Notes:</p> <ul style="list-style-type: none"> • If the "Maximum VOL level" is set lower than the "Initial VOL level", the "Initial VOL level" automatically becomes the same as the "Maximum VOL level". • The volume display can go up to 63 regardless of the settings. • You can hear the changed volume regardless of your volume setting before opening the options menu if you adjust the volume when "Maximum VOL level" is "On" and cursor is on the menu.

Item	Adjustments
INPUT lock	<p>Off ↔ PC ↔ INPUT1 ↔ INPUT2 ↔ INPUT3 Locks the input switch operation.</p> <p>Notes:</p> <ul style="list-style-type: none"> • Only the adjusted signal is displayed (see page 14). • Signal can be displayed when the Terminal board is installed. • Input switch can be used when this is set to "Off". • In two screen display mode, if anything other than "Off" is set, the value will be fixed as the value input in the single screen display mode. • When a dual input terminal board is attached, A or B is displayed depending on the selected input signal. (Ex. INPUT1A, INPUT1B)
Button lock	<p>Off ↔ MENU&ENTER ↔ On Off: All the buttons on main unit can be used. MENU&ENTER: Locks and buttons on main unit. On: Locks all the button on main unit. Sets Button lock with the unit buttons in the following procedure. Off: Press four times → Press four times → Press four times → Press four times → Press four times MENU&ENTER: Press four times → Press four times → Press four times → Press four times → Press four times On: Press four times → Press four times → Press four times → Press four times → Press four times</p>
Remocon User level	<p>Off ↔ User1 ↔ User2 ↔ User3 Off: You can use all of the buttons on the remote control. User1: You can only use , , , , , , , , , buttons on the remote control. User2: You can only use , buttons on the remote control. User3: Locks all the buttons on remote control.</p>
Off-timer function	<p>Enable: Enables the "Off-timer function". Disable: Disables the "Off-timer function". Note: When "Disable" is set, the Off-timer is cancelled.</p>
Initial Power Mode	<p>Normal ↔ Standby ↔ On Sets the power mode of the unit for when the power recovers from failure or after plugging off and in again. Normal: Power returns in as the same state as before the power interruption. Standby: Power returns in standby mode. (Power Indicator : red/orange) On: Power returns in power On. (Power Indicator : green) Note: When using multiple displays, "Standby" is preferred to be set in order to reduce a power load.</p>
ID select	<p>Sets panel ID number when panel is used in "Remote ID" or "Serial ID". Set value range: 0 - 100 (Standard value: 0)</p>
Remote ID	<p>Off: Disables ID remote control functions. You can use normal remote control operations. On: Enable ID remote control functions. Note: To use the ID remote control function, it is necessary to set each ID number of remote control and display unit. About the setting method, please refer to "ID Remote Control Function" (see page 33) and "ID select" (above-mentioned).</p>
Serial ID	<p>Sets the panel ID Control. Off: Disables external control by the ID. On: Enables the external control by the ID.</p>
Display size	<p>Adjusts the image display size on screen. Off: Sets the normal image display size on screen. On: Sets the image display size approximately 95 % of the normal image display.</p> <div style="display: flex; justify-content: space-around; align-items: center;"> <div style="text-align: center;"> <p>Off</p> </div> <div style="text-align: center;"> <p>On</p> </div> </div> <p>Notes:</p> <ul style="list-style-type: none"> • This setting is valid only when the input signals are as follows; NTSC, PAL, SECAM, M.NTSC, PAL60, PAL-M, PAL-N (BNC Dual Video Terminal Board (TY-FB9BD)) 525i, 525p, 625i, 625p, 750/60p, 750/50p, 1125/60i, 1125/50i, 1125/24sF, 1125/25p, 1125/24p, 1125/30p, 1125/60p, 1125/50p, 1250/50i (Component Video, RGB, DVI, SDI, HDMI) • This setting is invalid when two screen display, digital zoom, Multi display or Portrait display is selected. • When "Display size" is set to "On", "H-Pos" and "V-Pos" in "Pos. /Size" can be adjusted. • Refer to each board's operating instruction for DVI, SDI, HDMI's corresponding signals.

Options Adjustments

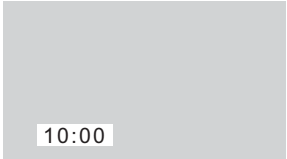
Item	Adjustments
Studio W/B	<p>Off: Nullify all the settings adjusted.</p> <p>On: Sets the white balance for TV studio.</p> <p>Note: Valid only when the “Warm” is set as “White balance” in Picture menu.</p>
Studio Gain	<p>Sharpens the contrast for a better view when a part of the image is too light to see.</p> <p>Off: Disables “Studio Gain”.</p> <p>On: Enables “Studio Gain”.</p> <p>Note: This setting is valid only when the input signals are as follows: Component Video, RGB (analog), SDI, HDMI</p>
Slot Power	<p>Off ↔ Auto ↔ On</p> <p>Off: Power is not transmitted to the slot power.</p> <p>Auto: Power is transmitted to the slot power only when main power is on.</p> <p>On: Power is transmitted to the slot power when main power is on or in the standby state.</p> <p>Note: In some cases, power is transmitted to the slot power when main power is on or in the standby state regardless of the slot power setting.</p>
Power On Screen Delay	<p>Off ↔ 1 ↔ 2 ↔ 3... ↔ 30</p> <p>You can set the power-on delay time of the displays to reduce the power load, when you press \odot/I to turn on the multiple displays that are set together, for example, on MULTI DISPLAY system. Set each display's setting individually.</p> <p>Off: The display will be turned on at the same time as \odot/I is pressed.</p> <p>1 to 30 (sec.): Set the power-on delay time (second). After pressing \odot/I, the display will be powered on with time delay depending on this setting.</p> <p>Notes:</p> <ul style="list-style-type: none"> • During this function is working, the power indicator is blinking green. • This function also works when the power recovers from failure or after plugging off and in again the power cord. <p>After you unplug and plug the power cord in while the unit is in standby mode and also the power is being supplied to a terminal board, the unit will start supplying the power to the board with time delay according to the setting.</p> <p>The power indicator lights up red first and it turns orange when the power starts being supplied to the board.</p>
Clock Display	<p>Off: Not display the clock.</p> <p>On: Display the clock.</p> <p>The clock is displayed at the lower left of the screen when \odot button is pressed.</p>  <p>Note: When “PRESENT TIME Setup” is not set, the clock is not displayed even if “Clock Display” is “On”. (see page 27)</p>
All Aspect	<p>Sets All Aspect mode (advanced aspect setting) or default aspect mode. With each press of \odot button, the aspect changes in the selected mode.</p> <p>Off: Default aspect mode</p> <p>On: All Aspect mode</p> <p>Aspect mode of each setting is as follows: (Example: HD signal)</p> <p>Off 4:3→4:3 Full→Zoom1→Zoom2→Zoom3→16:9→14:9→Just</p> <p>On 4:3 (1)→4:3 (2)→4:3 Full→Zoom1→Zoom2→Zoom3→16:9→14:9→Just1→Just2</p>
Rotate	<p>Off: Does not rotate the image.</p> <p>On: Rotates the image 180 degrees.</p>
Serial Slot Select	<p>Slot1 ↔ Slot2 ↔ Slot3</p> <p>Selects the slot which communicates serial.</p> <p>Note: The setting of an external command can be set only from the fixed serial terminal. (see page 10)</p>

Normalization

When both main unit buttons and remote control are disabled due to the “Button lock”, “Remocon User level” or “Remote ID” adjustments, set all the values “Off” so that all the buttons are enabled again.

Press the \square button on main unit together with \odot button on the remote control and hold for more than 5 seconds. The “SHIPPING” menu is displayed and the lock is released when it disappears.

Weekly Command Timer

You can set 7-day timer programming by setting time and command.

Note:

Before setting Weekly Command Timer, set PRESENT TIME Setup. (see page 27)

1

Press to select Function.
Press to select "On".

Note:

- When Function is set to On, Set up TIMER (see page 27) is unavailable and Interval / Time Designation in Mode of Screensaver (see page 28) cannot be selected.

2

Press to select a day.
Press to select a program number.

Note:

- You can set the program from 1 to 7. --- indicates unset.

3

Press to select Program Edit.
Press to show the Program Edit screen.

4

Press to select Program.
Press to change the program numbers (1-7).

5

Press to select a command number.
Press to show the previous / next command pages (1-8) of the selected program.
Press to show the command setting screen.



Press ACTION (■) button

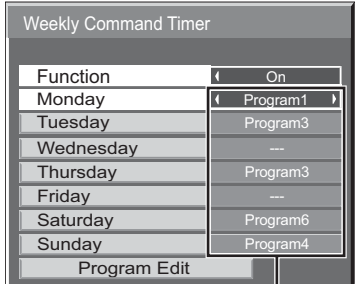

Program number

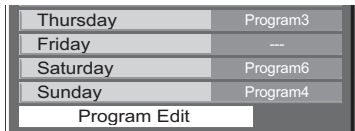

Program Edit screen

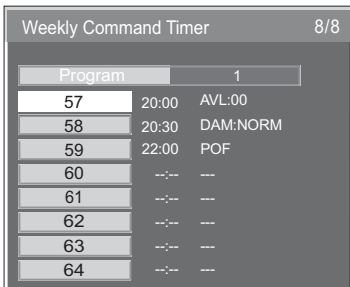
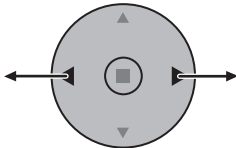
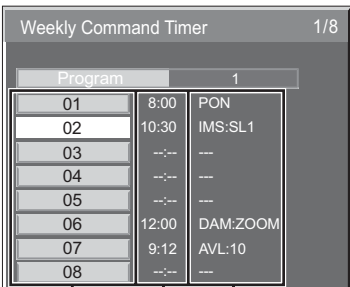
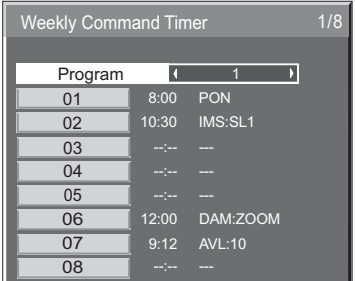

Command numbers
Command (--- indicates unset)
Set time of timer(--:-- indicates unset)

Options Adjustments

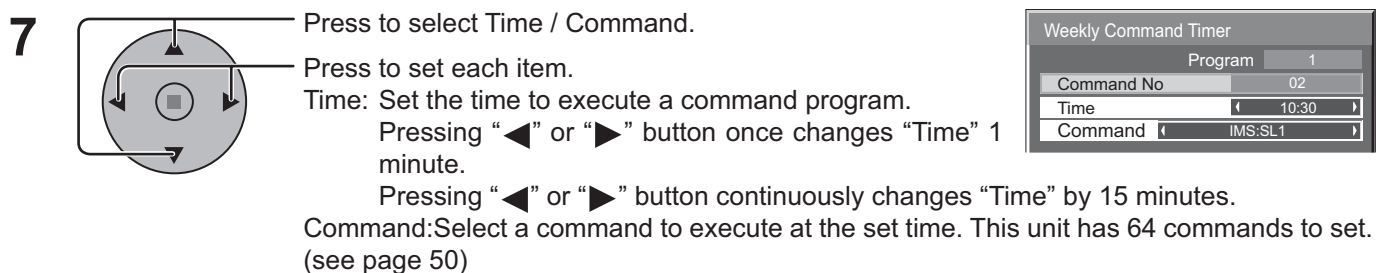
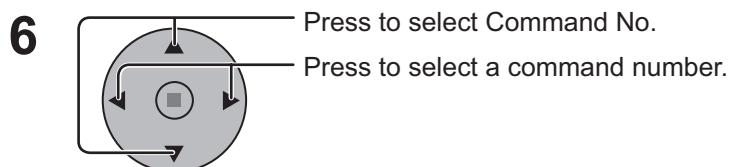

Command setting screen

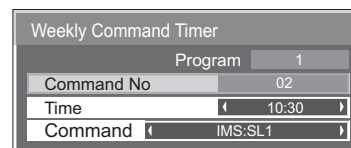
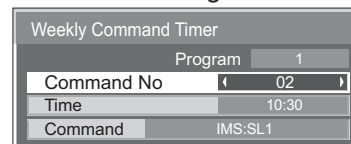

Notes:

- Command is performed in order of execution time, regardless of the command number.
- If a command execution time overlaps with that of other commands, these commands are performed in number order.
- Pressing \bigcirc^N , Time becomes --:-- and Command becomes ---.

Note:

Press \bigcirc^R to return to the previous screen.

Shipping condition

This function allows you to reset the unit to the factory setting.

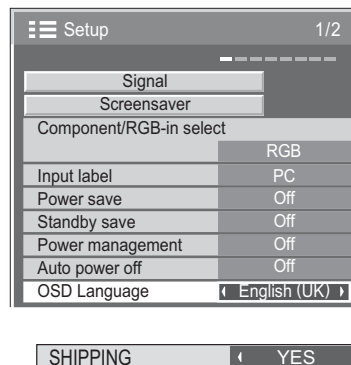
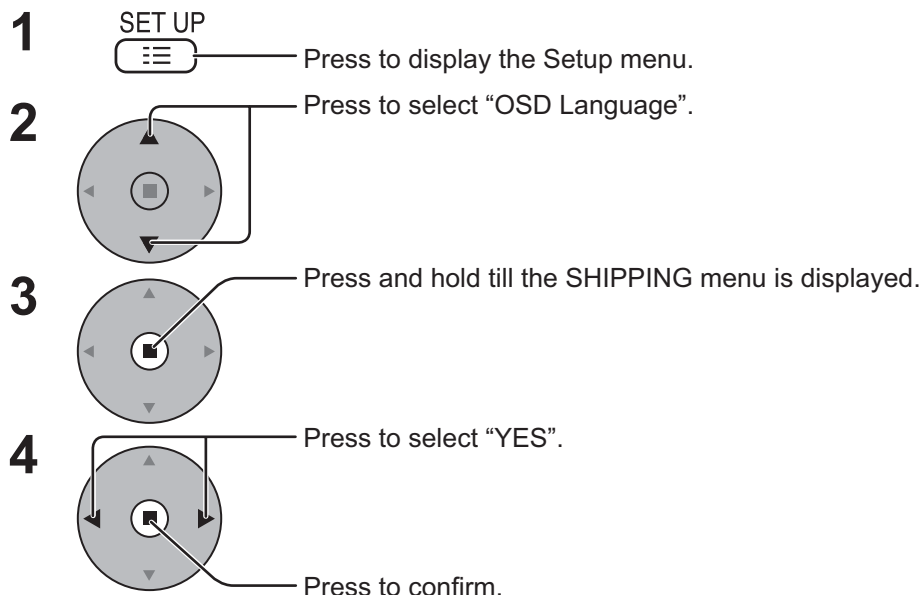

[from the unit]









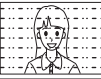

- 1 Press the MENU button till the Setup menu is displayed.
- 2 Press the Volume Up“+” or Down“-” button to select “OSD Language”.
- 3 Press and hold the ENTER button till the SHIPPING menu is displayed.
- 4 Press the Volume Up“+” or Down“-” button to select “YES”.
- 5 Press the ENTER button and wait for 10 sec.

Note:

Press the R button to return to Setup menu when SHIPPING menu is displayed.

Troubleshooting

Before you call for service, determine the symptoms and make a few simple checks as shown below.

Symptoms		Checks
Picture	Sound	
 Interference	 Noisy Sound	Electrical Appliances Cars / Motorcycles Fluorescent light
 Normal Picture	 No Sound	Volume (Check whether the mute function has been activated on the remote control.)
 No Picture	 No Sound	Not plugged into AC outlet Not switched on Picture and Brightness/Volume setting (Check by pressing the power switch or stand-by button on the remote control.)
 No Picture	 Normal Sound	If a signal with a non-applicable colour system format, or frequency is input, only the input terminal indication is displayed.
 No Colour	 Normal Sound	Colour controls set at minimum level (see page 24, 25) Colour system (see page 39)
No remote control operations can be performed.		Check whether the batteries have discharged completely and, if they have not, whether they were inserted properly. Check whether the remote control sensor is exposed to an outdoor light or a strong fluorescent light. Check whether the remote control designed specifically for use with the unit is being used. (The unit cannot be operated by any other remote control.)
A cracking sound is sometimes heard from the unit.		If there is nothing wrong with the picture or sound, this is the sound of the cabinet undergoing very slight contractions in response to changes in the room temperature. There are no adverse effects on the performance or other aspects.
The top or bottom of the picture on the screen is cut off when I use the zoom function.		Adjust the position of the picture on the screen.
Areas at the top and bottom of the screen where the image is missing appear when I use the zoom function.		When using a video software program (such as a cinema size program) with a screen wider than one in the 16:9 mode, blank areas separate from the images are formed at the top and bottom of the screen.
I can hear sounds coming from inside the unit.		When the power is turned on, a sound of the display panel being driven may be heard: This is normal and not indicative of malfunctioning.
This Plasma Display uses special image processing. Hence a slight time lag may occur between image and audio, depending on the type of input signal. However, this is not a malfunction.		

Plasma Display panel

Symptoms	Check
The screen darkens slightly when bright pictures with minimal movements are shown.	The screen will darken slightly when photos, still images of a computer or other pictures with minimal movements are shown for an extended period. This is done to reduce image retention on the screen and the shortening of the screen's service life: It is normal and not indicative of malfunctioning.
It takes a while for the picture to appear.	The unit digitally processes the various signals in order to reproduce esthetically pleasing images. As such, it sometimes takes a few moments for the picture to appear when the power has been turned on, when the input has been switched or when the images for the main picture and sub picture on the two screens are swapped.
The edges of the images flicker.	Due to the characteristics of the system used to drive the panel, the edges may appear to flicker in the fast-moving parts of the images: This is normal and not indicative of malfunctioning.
The brightness on both sides of images in the 4:3 mode changes.	When viewing the side panels at the "High" or "Mid" setting, the brightness on both sides may change depending on the kind of program shown: This is normal and not indicative of malfunctioning.
Some parts of the screen do not light up.	The plasma display panel is manufactured using an extremely high level of precision technology, however, sometimes some parts of the screen may be missing picture elements or have luminous spots. This is not a malfunction.
 Image retention appears	Do not allow a still picture to be displayed for an extended period, as this can cause a permanent image retention to remain on the Plasma Display. Examples of still pictures include logos, video games, computer images, teletext and images displayed in 4:3 mode. Note: The permanent image retention on the Plasma Display resulting from fixed image use is not an operating defect and as such is not covered by the Warranty. This product is not designed to display fixed images for extended periods of time.
Whirring sounds can be heard from the display unit.	The display unit is fitted with a cooling fan to dissipate heat generated during normal use. The whirring sound is caused by rotation of the fan and is not a malfunction.

List of Aspect Modes

Aspect mode		Picture → Enlarged screen	Description
All Aspect: On	Factory setting All Aspect: Off		
16:9	16:9		The display of the pictures fills the screen. In the case of SD signals, pictures with a 4:3 aspect ratio are enlarged horizontally, and displayed. This mode is suited to displaying anamorphic pictures with a 16:9 aspect ratio.
14:9	14:9		Letterbox pictures with a 14:9 aspect ratio are enlarged vertically and horizontally so that their display fills the screen vertically and is slightly smaller than the screen horizontally. The top and bottom edges of the pictures are cut off. Side panels are displayed at the left and right edges of the screen.
Just ----- Just1	Just		Pictures with a 4:3 aspect ratio are enlarged horizontally so that the picture distortion is minimized. The display of the areas around the left and right edges of the screen is slightly elongated.
Just2	—		The pictures with a 4:3 aspect ratio among the 16:9 aspect ratio signals are enlarged horizontally so that the picture distortion is minimized. The left and right edges of the pictures are cut off. The display of the areas around the left and right edges of the screen is slightly elongated.
4:3 ----- 4:3 (1)	4:3		Pictures with a 4:3 aspect ratio are displayed with their original aspect ratio. Side panels are displayed at the left and right edges of the screen.
4:3 (2)	—		The pictures with a 4:3 aspect ratio among the 16:9 aspect ratio signals are displayed with their original aspect ratio. The left and right edges of the pictures are masked with side panels.
4:3 Full	4:3 Full		The pictures with a 4:3 aspect ratio among the 16:9 aspect ratio signals are enlarged horizontally so that their display fills the screen. The left and right edges of the pictures are cut off.
Zoom ----- Zoom1	Zoom1		Letterbox pictures with a 16:9 aspect ratio are enlarged vertically and horizontally so that their display fills the screen. The top and bottom edges of the pictures are cut off.
Zoom2	Zoom2		The letterbox pictures with a 2.35:1 aspect ratio among the 16:9 aspect ratio signals are enlarged vertically and horizontally so that their display fills the screen. The top and bottom edges as well as the left and right edges of the pictures are cut off.
Zoom3	Zoom3		Letterbox pictures with a 2.35:1 aspect ratio are enlarged vertically and horizontally so that their display fills the screen vertically and is slightly larger than the screen horizontally. The top and bottom edges as well as the left and right edges of the pictures are cut off.

Applicable Input Signals

	Signal name	Horizontal frequency (kHz)	Vertical frequency (Hz)	Component / RGB / Mini D-sub 15P (Dot clock (MHz))	DVI-D (Dot clock (MHz))
1	525 (480) / 60i	15.73	59.94	* (13.5)	
2	525 (480) / 60p	31.47	59.94	* (27.0) *5	* (27.0)
3	625 (575) / 50i	15.63	50.00	* (13.5)	
4	625 (575) / 50p	31.25	50.00	* (27.0)	
5	625 (576) / 50p	31.25	50.00		* (27.0)
6	750 (720) / 60p	45.00	60.00	* (74.25)	* (74.25)
7	750 (720) / 50p	37.50	50.00	* (74.25)	* (74.25)
8	1,125 (1,080) / 60p	67.50	60.00	* (148.5) *1	* (148.5)
9	1,125 (1,080) / 60i	33.75	60.00	* (74.25) *1	* (74.25)
10	1,125 (1,080) / 50p	56.26	50.00	* (148.5) *1	* (148.5)
11	1,125 (1,080) / 50i	28.13	50.00	* (74.25) *1	* (74.25)
12	1,125 (1,080) / 24sF	27.00	48.00	* (74.25) *2	
13	1,125 (1,080) / 30p	33.75	30.00	* (74.25) *1	* (74.25)
14	1,125 (1,080) / 25p	28.13	25.00	* (74.25) *1	* (74.25)
15	1,125 (1,080) / 24p	27.00	24.00	* (74.25) *1	* (74.25)
16	1,250 (1,080) / 50i	31.25	50.00	* (74.25) *3	
17	2,048 × 1,080 / 24sF *7	27.00	48.00		
18	2,048 × 1,080 / 24p *7	27.00	24.00		
19	640 × 400 @70 Hz	31.46	70.07	* (25.17)	
20	640 × 480 @60 Hz	31.47	59.94	* (25.18) *6	* (25.18)
21	640 × 480 @72 Hz	37.86	72.81	* (31.5)	
22	640 × 480 @75 Hz	37.50	75.00	* (31.5)	
23	640 × 480 @85 Hz	43.27	85.01	* (36.0)	
24	800 × 600 @56 Hz	35.16	56.25	* (36.0)	
25	800 × 600 @60 Hz	37.88	60.32	* (40.0)	* (40.0)
26	800 × 600 @72 Hz	48.08	72.19	* (50.0)	
27	800 × 600 @75 Hz	46.88	75.00	* (49.5)	
28	800 × 600 @85 Hz	53.67	85.06	* (56.25)	
29	852 × 480 @60 Hz	31.47	59.94	* (33.54) *6	* (34.24)
30	1,024 × 768 @50 Hz	39.55	50.00		* (51.89)
31	1,024 × 768 @60 Hz	48.36	60.00	* (65.0)	* (65.0)
32	1,024 × 768 @70 Hz	56.48	70.07	* (75.0)	
33	1,024 × 768 @75 Hz	60.02	75.03	* (78.75)	
34	1,024 × 768 @85 Hz	68.68	85.00	* (94.5)	
35	1,066 × 600 @60 Hz	37.64	59.94	* (53.0)	* (53.0)
36	1,152 × 864 @60 Hz	53.70	60.00		* (81.62)
37	1,152 × 864 @75 Hz	67.50	75.00	* (108.0)	
38	1,280 × 768 @60 Hz	47.70	60.00	* (80.14)	
39	1,280 × 960 @60 Hz	60.00	60.00	* (108.0)	
40	1,280 × 960 @85 Hz	85.94	85.00	* (148.5)	
41	1,280 × 1,024 @60 Hz	63.98	60.02	* (108.0)	* (108.0)
42	1,280 × 1,024 @75 Hz	79.98	75.03	* (135.0)	
43	1,280 × 1,024 @85 Hz	91.15	85.02	* (157.5)	
44	1,366 × 768 @50 Hz	39.55	50.00		* (69.92)
45	1,366 × 768 @60 Hz	48.36	60.00	* (86.71)	* (87.44)
46	1,400 × 1,050 @60 Hz	65.22	60.00		* (122.61)
47	1,600 × 1,200 @60 Hz	75.00	60.00	* (162.0)	* (162.0)
48	1,600 × 1,200 @65 Hz	81.25	65.00	* (175.5)	
49	1,920 × 1,080 @60 Hz	67.50	60.00	* (148.5) *4	* (148.5)
50	1,920 × 1,200 @60 Hz	74.04	59.95		* (154.0)
51	Macintosh13" (640 × 480)	35.00	66.67	* (30.24)	
52	Macintosh16" (832 × 624)	49.72	74.54	* (57.28)	
53	Macintosh21" (1,152 × 870)	68.68	75.06	* (100.0)	

*1: Based on SMPTE 274M standard.

*2: Based on SMPTE RP211 standard.

*3: Based on SMPTE 295M standard.

*4: The input signal is recognized as 1,125 (1,080) / 60p.

*5: When selected the RGB format and 525p signal input to the Mini D-sub 15P terminal, it is recognized as VGA 60Hz signal.

*6: When inputted VGA 60Hz format signal from the other than Mini D-sub 15P terminal, it is recognized as 525p signal.

*7: Based on SMPTE 292M and 372M standards. These signals can be received when the Dual Link HD-SDI Terminal Board (TY-FB11DHD) is installed.

Note: Signals without above specification may not be displayed properly.

Command list of Weekly Command Timer

No.	Command	Control details
1	AAC:MENCLR	Audio Menu (Clear)
2	AAC:MENDYN	Audio Menu (Dynamic)
3	AAC:MENSTD	Audio Menu (Standard)
4	AAC:SURMON	Surround (ON)
5	AAC:SUROFF	Surround (OFF)
6	AMT:0	Audio Mute (OFF)
7	AMT:1	Audio Mute (ON)
8	ASO:M	Audio out when PIP mode (Main Picture)
9	ASO:S	Audio out when PIP mode (Sub Picture)
10	AVL:00	Audio Volume (00)
11	AVL:10	Audio Volume (10)
12	AVL:20	Audio Volume (20)
13	AVL:30	Audio Volume (30)
14	AVL:40	Audio Volume (40)
15	AVL:50	Audio Volume (50)
16	AVL:60	Audio Volume (60)
17	DAM:FULL	Aspect (16:9)
18	DAM:JUST	Aspect (Just)
19	DAM:NORM	Aspect (4:3)
20	DAM:SELF	Aspect (Panasonic Auto)
21	DAM:ZOOM	Aspect (Zoom)
22	DWA:OFF	Advanced PIP mode (OFF)
23	DWA:OVL1	Advanced PIP mode (1) (see page 18)
24	DWA:OVL2	Advanced PIP mode (2) (see page 18)
25	DWA:OVL3	Advanced PIP mode (3) (see page 18)
26	DWA:OVL4	Advanced PIP mode (4) (see page 18)
27	DWA:OVL5	Advanced PIP mode (5) (see page 18)
28	DWA:OVL6	Advanced PIP mode (6) (see page 18)
29	DWA:OVLOF	Advanced PIP mode (OFF) (normal two screen display mode)
30	DWA:OVLON	Advanced PIP mode (ON)
31	DWA:PIN0	The location of the sub picture (lower right)
32	DWA:PIN1	The location of the sub picture (lower left)
33	DWA:PIN2	The location of the sub picture (upper left)
34	DWA:PIN3	The location of the sub picture (upper right)
35	DWA:PIP	Dual Picture mode (Picture in Picture)
36	DWA:POP	Dual Picture mode (Picture out Picture)
37	DWA:SWP	Swap main picture and sub picture when PIP mode
38	DWA:TWN	Dual Picture mode (Picture and Picture)
39	IMS:PC1	Input select (PC1) (Main Picture when PIP mode)
40	IMS:SL1	Input select (SLOT1) (Main Picture when PIP mode)
41	IMS:SL1A	Input select (SLOT1A) (Main Picture when PIP mode)
42	IMS:SL1B	Input select (SLOT1B) (Main Picture when PIP mode)
43	IMS:SL2	Input select (SLOT2) (Main Picture when PIP mode)
44	IMS:SL2A	Input select (SLOT2A) (Main Picture when PIP mode)
45	IMS:SL2B	Input select (SLOT2B) (Main Picture when PIP mode)
46	IMS:SL3	Input select (SLOT3) (Main Picture when PIP mode)
47	ISS:PC1	Sub Picture Input Select (PC1)
48	ISS:SL1	Sub Picture Input Select (SLOT1)
49	ISS:SL1A	Sub Picture Input Select (SLOT1A)
50	ISS:SL1B	Sub Picture Input Select (SLOT1B)
51	ISS:SL2	Sub Picture Input Select (SLOT2)
52	ISS:SL2A	Sub Picture Input Select (SLOT2A)
53	ISS:SL2B	Sub Picture Input Select (SLOT2B)
54	ISS:SL3	Sub Picture Input Select (SLOT3)
55	OSP:SCR0	Screen Saver Scrolling bar only (OFF)
56	OSP:SCR1	Screen Saver Scrolling bar only (ON)
57	POF	Power OFF
58	PON	Power ON
59	SSC:FNC0	Screen Saver function (Scrolling bar only)
60	SSC:FNC1	Screen Saver function (Negative image)
61	SSC:MOD0	Screen Saver (Mode (OFF))
62	SSC:MOD3	Screen Saver (Mode (ON))
63	VMT:0*	Picture Mute (OFF)
64	VMT:1*	Picture Mute (ON)

* Picture Mute cannot be unlocked by powering off/on with the remote control. Turn off and on again with the button on the unit or enter the command VMT:0 to unlock Picture Mute.

Specifications

	TH-42PF11EK	TH-50PF11EK
Power Source	220 - 240 V AC, 50/60 Hz	
Power Consumption		
Power on	410 W	485 W
Stand-by condition	Save off 1.2 W, Save on 0.7 W	Save off 1.2 W, Save on 0.7 W
Power off condition	0.4 W	0.4 W
Plasma Display panel	Drive method : AC type 42-inch, 16:9 aspect ratio	Drive method : AC type 50-inch, 16:9 aspect ratio
Screen size	922 mm (W) × 518 mm (H) × 1,057 mm (diagonal)	1,106 mm (W) × 622 mm (H) × 1,269 mm (diagonal)
(No. of pixels)	2,073,600 (1,920 (W) × 1,080 (H)) [5,760 × 1,080 dots]	
Operating condition		
Temperature	0 °C - 40 °C	
Humidity	20 % - 80 %	
Applicable signals		
Scanning format	525 (480) / 60i · 60p, 625 (575) / 50i · 50p, 750 (720) / 60p · 50p, 1125 (1080) / 60i · 60p · 50i · 50p · 24p · 25p · 30p · 24sF, 1250 (1080) / 50i	
PC signals	VGA, SVGA, XGA, SXGA UXGA ... (compressed) Horizontal scanning frequency 15 - 110 kHz Vertical scanning frequency 48 - 120 Hz	
Connection terminals		
DVI-D IN	Video Input Audio Input Content Protection	DVI-D 24 Pin x 1 compliance with DVI Revision 1.0 * Refer to page 11 for applicable signals Stereo mini jack (M3) x 1 0.5 Vrms Compatible with HDCP 1.1
COMPONENT/RGB IN	Y/G (BNC) P _B /B (BNC), P _R /R (BNC) AUDIO IN (RCA PIN JACK × 2)	with sync 1.0 Vp-p (75 Ω) 0.7 Vp-p (75 Ω) 0.5 Vrms
PC IN	(HIGH-DENSITY MINI D-SUB 15PIN) VBS (use HD port) AUDIO IN (M3 JACK)	Y or G with sync 1.0 Vp-p (75 Ω) Y or G without sync 0.7 Vp-p (75 Ω) B/P _B /C _B : 0.7 Vp-p (75 Ω) R/P _R /C _R : 0.7 Vp-p (75 Ω) HD/VD: 1.0 - 5.0 Vp-p (high impedance) with picture 1.0 Vp-p (high impedance) without picture 0.3 Vp-p (high impedance) 0.5 Vrms
SERIAL	EXTERNAL CONTROL TERMINAL (D-SUB 9PIN)	RS-232C COMPATIBLE
SPEAKERS	6 Ω, 16 W [8 W + 8 W] (10 % THD)	
Accessories Supplied		
Remote Control Transmitter	EUR7636090R	
Batteries	2 × R6 Size	
Fixing band	TMME203 × 1	
Dimensions (W × H × D)	1,020 mm × 610 mm × 99 mm	1,210 mm × 724 mm × 95 mm
Mass (weight)		
main unit only	approx. 29.0 kg net	approx. 36.0 kg net
with speakers	approx. 33.0 kg	approx. 40.0 kg

Notes:

- Design and specifications are subject to change without notice. Mass and dimensions shown are approximate.
- This equipment complies with the EMC standards listed below.
EN55022, EN55024, EN61000-3-2, EN61000-3-3.

Specifications

	TH-58PF11EK	TH-65PF11EK
Power Source	220 - 240 V AC, 50/60 Hz	
Power Consumption		
Power on	625 W	710 W
Stand-by condition	Save off 1.2 W, Save on 0.7 W	Save off 1.2 W, Save on 0.7 W
Power off condition	0.4 W	0.4 W
Plasma Display panel	Drive method : AC type 58-inch, 16:9 aspect ratio	Drive method : AC type 65-inch, 16:9 aspect ratio
Screen size	1,284 mm (W) × 723 mm (H) × 1,474 mm (diagonal)	1,434 mm (W) × 807 mm (H) × 1,646 mm (diagonal)
(No. of pixels)	2,073,600 (1,920 (W) × 1,080 (H)) [5,760 × 1,080 dots]	
Operating condition		
Temperature	0 °C - 40 °C	
Humidity	20 % - 80 %	
Applicable signals		
Scanning format	525 (480) / 60i · 60p, 625 (575) / 50i · 50p, 750 (720) / 60p · 50p, 1125 (1080) / 60i · 60p · 50i · 50p · 24p · 25p · 30p · 24sF, 1250 (1080) / 50i	
PC signals	VGA, SVGA, XGA, SXGA UXGA (compressed) Horizontal scanning frequency 15 - 110 kHz Vertical scanning frequency 48 - 120 Hz	
Connection terminals		
DVI-D IN	Video Input Audio Input Content Protection	DVI-D 24 Pin x 1 compliance with DVI Revision 1.0 * Refer to page 11 for applicable signals Stereo mini jack (M3) x 1 0.5 Vrms Compatible with HDCP 1.1
COMPONENT/RGB IN	Y/G (BNC) P _B /B (BNC), P _R /R (BNC) AUDIO IN (RCA PIN JACK × 2)	with sync 1.0 Vp-p (75 Ω) 0.7 Vp-p (75 Ω) 0.5 Vrms
PC IN	(HIGH-DENSITY MINI D-SUB 15PIN) VBS (use HD port) AUDIO IN (M3 JACK)	Y or G with sync 1.0 Vp-p (75 Ω) Y or G without sync 0.7 Vp-p (75 Ω) B/P _B /C _B : 0.7 Vp-p (75 Ω) R/P _R /C _R : 0.7 Vp-p (75 Ω) HD/VD: 1.0 - 5.0 Vp-p (high impedance) with picture 1.0 Vp-p (high impedance) without picture 0.3 Vp-p (high impedance) 0.5 Vrms
SERIAL	EXTERNAL CONTROL TERMINAL (D-SUB 9PIN)	RS-232C COMPATIBLE
SPEAKERS	6 Ω, 16 W [8 W + 8 W] (10 % THD)	8 Ω, 20 W [10 W + 10 W] (10 % THD)
Accessories Supplied		
Remote Control Transmitter	EUR7636090R	
Batteries	2 × R6 Size	
Fixing band	TMME203 × 1	
Dimensions (W × H × D)	1,399 mm × 843 mm × 99 mm	1,554 mm × 925 mm × 99 mm
Mass (weight)		
main unit only	approx. 54.5 kg net	approx. 68.0 kg net
with speakers	approx. 59.5 kg	approx. 74.0 kg

Notes:

- Design and specifications are subject to change without notice. Mass and dimensions shown are approximate.
- This equipment complies with the EMC standards listed below.
EN55022, EN55024, EN61000-3-2, EN61000-3-3.

Memo

A series of horizontal dashed lines for writing.

Information for Users on Collection and Disposal of Old Equipment and used Batteries



These symbols on the products, packaging, and/or accompanying documents mean that used electrical and electronic products and batteries should not be mixed with general household waste. For proper treatment, recovery and recycling of old products and used batteries, please take them to applicable collection points, in accordance with your national legislation and the Directives 2002/96/EC and 2006/66/EC.

By disposing of these products and batteries correctly, you will help to save valuable resources and prevent any potential negative effects on human health and the environment which could otherwise arise from inappropriate waste handling.

For more information about collection and recycling of old products and batteries, please contact your local municipality, your waste disposal service or the point of sale where you purchased the items. Penalties may be applicable for incorrect disposal of this waste, in accordance with national legislation.



For business users in the European Union

If you wish to discard electrical and electronic equipment, please contact your dealer or supplier for further information.



[Information on Disposal in other Countries outside the European Union]

These symbols are only valid in the European Union. If you wish to discard these items, please contact your local authorities or dealer and ask for the correct method of disposal.

Note for the battery symbol (bottom two symbol examples):

This symbol might be used in combination with a chemical symbol. In this case it complies with the requirement set by the Directive for the chemical involved.

Cd

Customer's Record

The model number and serial number of this product can be found on its rear panel. You should note this serial number in the space provided below and retain this book, plus your purchase receipt, as a permanent record of your purchase to aid in identification in the event of theft or loss, and for Warranty Service purposes.

Model Number _____

Serial Number _____

Panasonic Corporation

Web Site : <http://panasonic.net/>

© Panasonic Corporation 2008

Printed in Czech Republic