

System Configuration Example

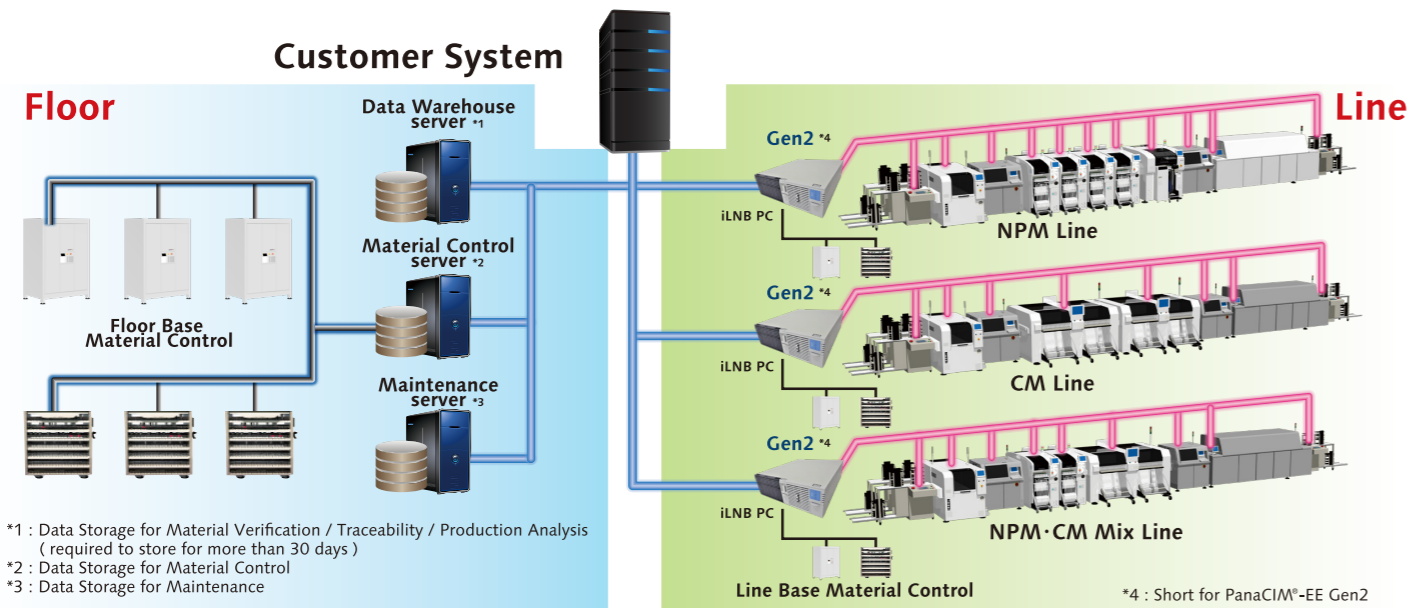

Features

Functionality	Description
Material Verification	Enables the verification of components at equipment level through writing component data on feeder memory. This also controls the start of production and prevents component misplacement. External interface to a customer's in-house systems available.
Material Control	This manages the data of components consumed on production floor. Using Reel ID (unique ID on each component), it tracks the exact number of remaining components and helps minimize inventory. Reservation and Allocation assures availability and MSD (moisture sensitive device) control is also available with life time management.
Traceability	This functionality provides easy search and filter capability for bad components and lots that would potentially cause recalls. Leveraging Material Control functionality, more detailed PCB identification is also available.
Production Monitoring / Dispatch	The real-time monitoring and visualization of equipment performance status works on PC monitors and also sends warnings and alerts to wireless handy terminals. It encourages operators to cope with component shortages and errors and reduces production downtime. Dispatch functionality (optional) navigates and optimizes the operator's travel route and component replenishment sequence to reduce component shortages that cause short time downtime and to save replenishment labor.
Production Analysis	By comparing each production line status, it identifies production performance trends and detects the bottleneck and root cause of the underperformance. It also increases production quality by obtaining inspection results from inspection equipment and identifying specific mounting conditions on bad components.
Maintenance	This promotes periodic maintenance of equipment and prevents production stop due to equipment errors. It also prevents bad equipment from being used in production and contributes to utilization increase when bad feeders are detected at offline setup.
Enterprise Link	The data export such as traceability and material verification to customer systems can be done through this functionality. Various interfaces such as file, socket and database are supported and can provide flexible integration with customer systems.

※ System structure may differ due to customer environment and equipment. Ask for more details.
 ※ Some of the equipment are prepared by customer.
 ※ There may be some restrictions for some functionality. Ask for more details.

⚠ Safety Cautions

- Please read the User's Manual carefully to familiarize yourself with safe and effective usage procedures.
- To ensure safety when using this equipment, all work should be performed according to that as stated in the supplied Operating Instructions. Read your operating instruction manual thoroughly.

Panasonic Group products are built with the environment in mind.

For details here



Panasonic GREEN IMPACT

Inquiries...

Panasonic Connect Co., Ltd.
Process Automation Business Division

Shiodome Hamarikyu Bldg., 8-21-1 Ginza, Chuo-ku, Tokyo 104-0061, Japan

All data as of April 1, 2024

Ver. April 1, 2024

© Panasonic Connect Co., Ltd. 2024

- Changes in specifications and appearance may be made without notice for product improvement.
- Please contact us via our website at <https://industrial.panasonic.com/ww/r/fw>

Panasonic CONNECT

2024

Electronics Assembly System

Mounting MES Software

Catalogue

Model ID

PanaCIM®-EE Gen2

Model No.

NM-EJS7B

Next Generation, Smart Factory Solution Integrating Cyber and Physical Layers!

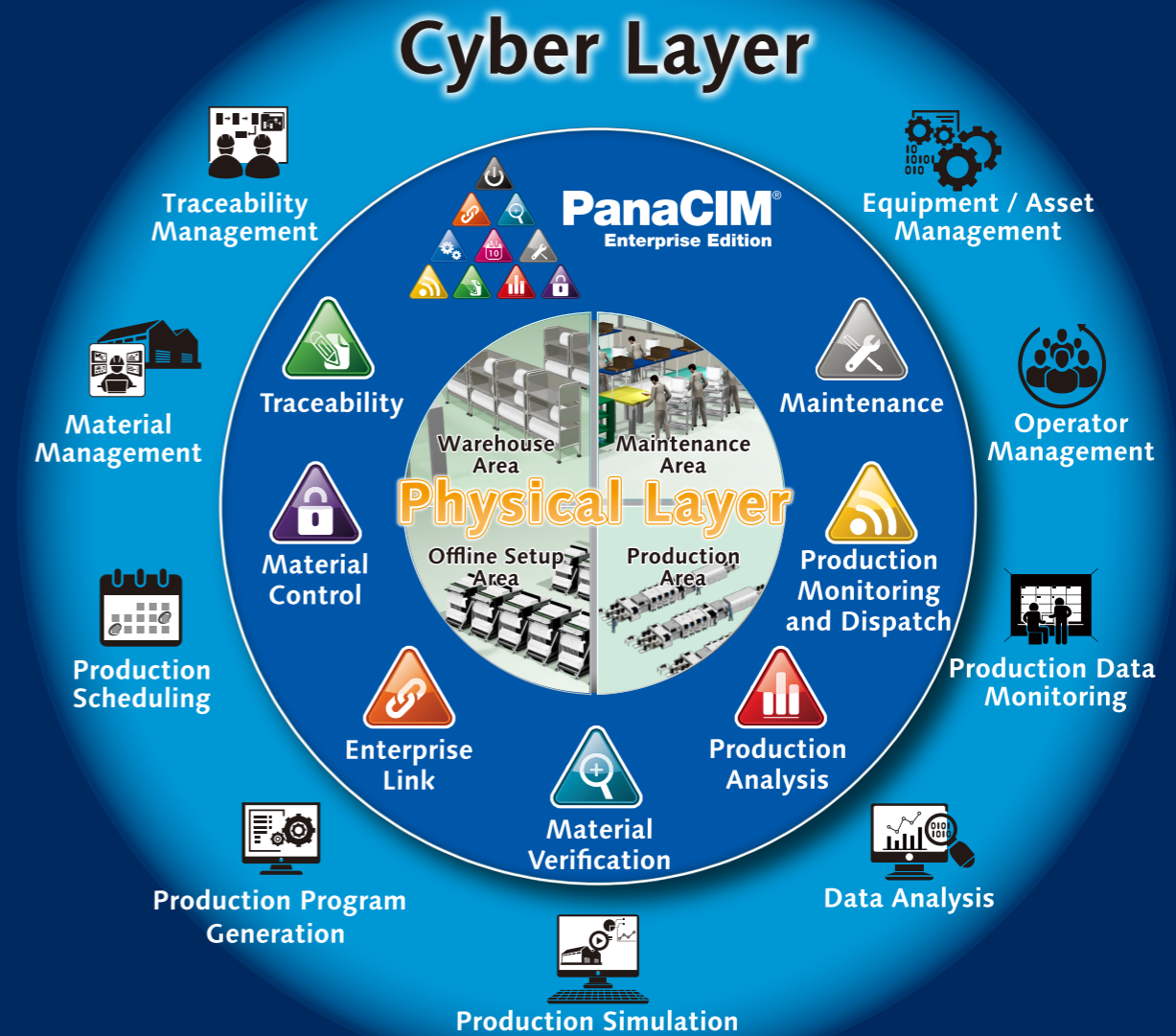

Next Generation , Smart Factory Solution Connecting Shop Floor with Management System Management

Precise Inventory Management



Real-time Consumption Monitoring

Maximize Factory Performance



Visualization and Analysis

Absolute Traceability

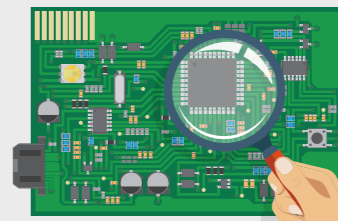

Reference Level

Enterprise Management Solution

PanaCIM®-EE Gen2



Flexible System Integration

- Production Scheduler
- ERP / MES

Flexible System Structure

- Small to Large Enterprises
- Rich Functional Modules

Accurate Material Supply

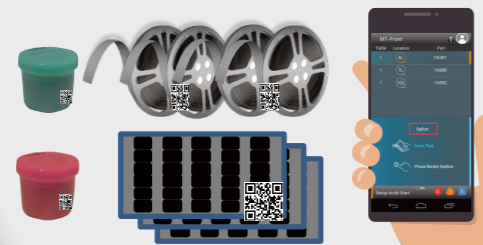

Error Prevention

Real-time Instruction



Operation Optimization

Continuous Production

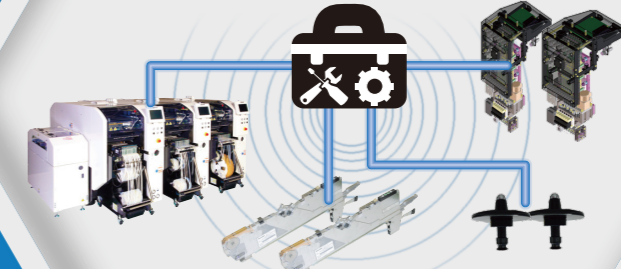

Asset Management & Preventive Maintenance

Gemba

Innovating SMT Shop Floor Operations!