

This zoom lens is designed for use with Panasonic's applicable projectors.

**Please use the lens only on the specified Panasonic projector.*

Specifications (Specifications subject to change without notice.)

F-number	2.1	
Focal distance (f)	5.4 mm - 5.8 mm [7/32 - 15/64 in]	
Throw ratio	0.308 - 0.330:1 (16:10 aspect ratio)	
	0.308 - 0.331:1 (16:9 aspect ratio)	
	0.371 - 0.398:1 (4:3 aspect ratio)	
Dimensions	Width	130 mm [5 1/8 in]
	Height	139 mm [5 15/32 in]
	Depth	477 mm [18 25/32 in]
Weight	4.7 kg (10.36 lb)	
Applicable projector	PT-REQ12L/PT-REQ10L/PT-REQ80L/PT-REZ12L/PT-REZ10L/PT-REZ80L	

Dimensions

unit : mm [inch]
This illustration is not drawn to scale.

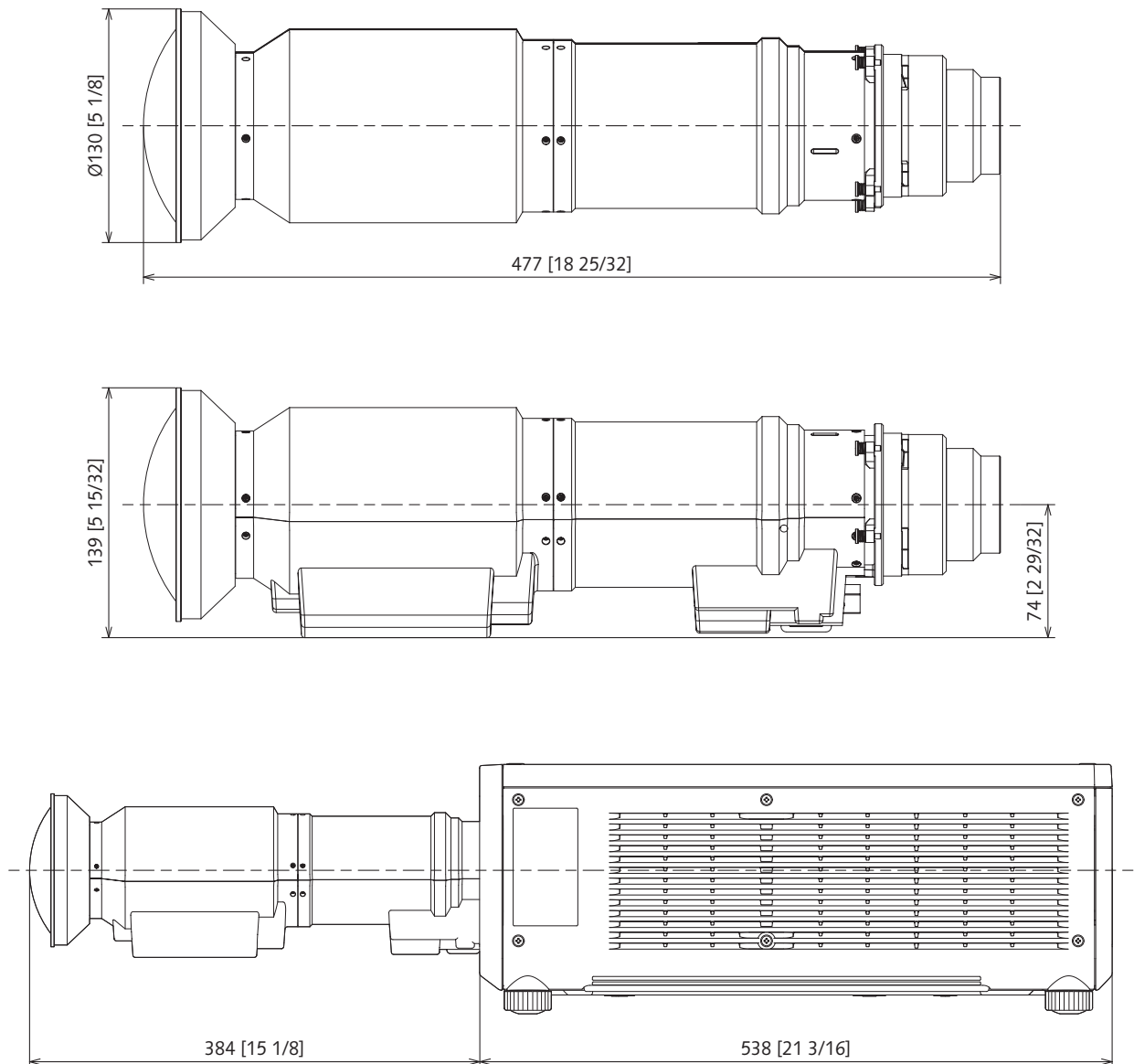

Dimensional relationship diagram

The dimensional relationship between the screen and the projector is shown below.

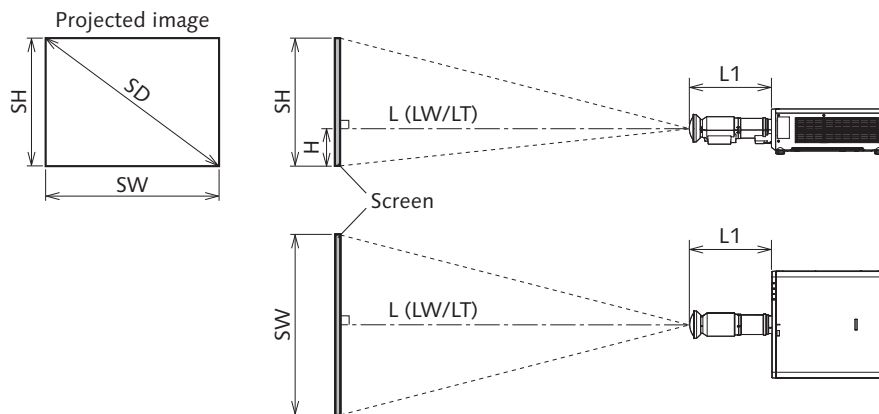

Note

- This illustration is prepared on the assumption that the projected image size and position have been aligned to fit full in the screen.
- This illustration is not drawn to scale.
- The values are approximate.

SH	Projected image height
SW	Projected image width
SD	Projected image size
H	Distance from the lens center to the bottom edge of the projected image
L	Projection distance (distance from the front end of the projection lens to the screen)
	LW Minimum projection distance when the Zoom Lens is used
	LT Maximum projection distance when the Zoom Lens is used
L1	Lens protrusion dimension (distance from the front surface of the projector to the front end of the projection lens)

Unit : m

Projector model	Dimension for L1 (approximate value)
PT-REQ12/PT-REQ10/PT-REQ80	0.384
PT-REZ12/PT-REZ10/PT-REZ80	

Projection distance

A $\pm 5\%$ error in listed projection distances may occur.

When [SCREEN ADJUSTMENT] is used, the image size is corrected to become smaller than the specified one.

Screen aspect ratio 16:10

Unit: meters

Projector model				PT-REQ12/PT-REQ10/PT-REQ80 PT-REZ12/PT-REZ10/PT-REZ80		PT-REQ12/PT-REQ10/PT-REQ80 PT-REZ12/PT-REZ10/PT-REZ80
Throw ratio				0.308 - 0.330:1		
Projected image size				Projection distance (L)		Height position (H)
Diagonal (SD)		Height (SH)	Width (SW)	Min. (LW)	Max. (LT)	
m	inches					
2.54	100	1.346	2.154	0.65	0.70	0.00 - 1.35
3.05	120	1.615	2.585	0.79	0.85	0.00 - 1.62
3.81	150	2.019	3.231	0.99	1.07	0.00 - 2.02
5.08	200	2.692	4.308	1.34	1.44	0.00 - 2.69
6.35	250	3.365	5.385	1.68	1.80	0.00 - 3.37
7.62	300	4.039	6.462	2.02	2.17	0.00 - 4.04
8.89	350	4.712	7.539	2.37	2.54	0.00 - 4.71
10.16	400	5.385	8.616	2.71	2.91	0.00 - 5.39
12.70	500	6.731	10.770	3.39	3.64	0.00 - 6.73
15.24	600	8.077	12.923	4.08	4.38	0.00 - 8.08
17.78	700	9.423	15.077	4.77	5.11	0.00 - 9.42
20.32	800	10.770	17.231	5.45	5.85	0.00 - 10.77
22.86	900	12.116	19.385	6.14	6.58	0.00 - 12.12
25.40	1000	13.462	21.539	6.82	7.32	0.00 - 13.46

- The throw ratio is based on the value during projection with the projected image size of 3.81 m [150 in].
- Fine text and images may not be displayed clearly during projection with the projected image size over 15.24 m [600 in].

Screen aspect ratio 16:10

Unit: feet

Projector model				PT-REQ12/PT-REQ10/PT-REQ80 PT-REZ12/PT-REZ10/PT-REZ80		PT-REQ12/PT-REQ10/PT-REQ80 PT-REZ12/PT-REZ10/PT-REZ80
Throw ratio				0.308 - 0.330:1		
Projected image size				Projection distance (L)		Height position (H)
Diagonal (SD)		Height (SH)	Width (SW)	Min. (LW)	Max. (LT)	
m	inches					
2.54	100	4.42	7.07	2.13	2.30	0.00 - 4.43
3.05	120	5.30	8.48	2.59	2.79	0.00 - 5.32
3.81	150	6.62	10.60	3.25	3.51	0.00 - 6.63
5.08	200	8.83	14.13	4.40	4.72	0.00 - 8.83
6.35	250	11.04	17.67	5.51	5.91	0.00 - 11.06
7.62	300	13.25	21.20	6.63	7.12	0.00 - 13.26
8.89	350	15.46	24.73	7.78	8.33	0.00 - 15.45
10.16	400	17.67	28.27	8.89	9.55	0.00 - 17.68
12.70	500	22.08	35.34	11.12	11.94	0.00 - 22.08
15.24	600	26.50	42.40	13.39	14.37	0.00 - 26.51
17.78	700	30.92	49.47	15.65	16.77	0.00 - 30.91
20.32	800	35.34	56.53	17.88	19.19	0.00 - 35.34
22.86	900	39.75	63.60	20.14	21.59	0.00 - 39.76
25.40	1000	44.17	70.67	22.38	24.02	0.00 - 44.16

- The throw ratio is based on the value during projection with the projected image size of 3.81 m [150 in].
- Fine text and images may not be displayed clearly during projection with the projected image size over 15.24 m [600 in].

Screen aspect ratio 16:9

Unit: meters

Projector model				PT-REQ12/PT-REQ10/PT-REQ80 PT-REZ12/PT-REZ10/PT-REZ80		PT-REQ12/PT-REQ10/PT-REQ80 PT-REZ12/PT-REZ10/PT-REZ80
Throw ratio				0.308 - 0.331:1		
Projected image size				Projection distance (L)		Height position (H)
Diagonal (SD)		Height (SH)	Width (SW)	Min. (LW)	Max. (LT)	
m	inches					
2.54	100	1.245	2.214	0.67	0.72	-0.07 - 1.31
3.05	120	1.494	2.657	0.81	0.87	-0.08 - 1.58
3.81	150	1.868	3.321	1.02	1.10	-0.10 - 1.97
5.08	200	2.491	4.428	1.38	1.48	-0.14 - 2.63
6.35	250	3.113	5.535	1.73	1.85	-0.17 - 3.29
7.62	300	3.736	6.641	2.08	2.23	-0.21 - 3.94
8.89	350	4.358	7.748	2.43	2.61	-0.24 - 4.60
10.16	400	4.981	8.855	2.78	2.99	-0.28 - 5.26
12.70	500	6.226	11.069	3.49	3.74	-0.35 - 6.57
15.24	600	7.472	13.283	4.19	4.50	-0.42 - 7.89
17.78	700	8.717	15.497	4.90	5.26	-0.48 - 9.20
20.32	800	9.962	17.710	5.60	6.01	-0.55 - 10.52
22.86	900	11.207	19.924	6.31	6.77	-0.62 - 11.83
25.40	1000	12.453	22.138	7.01	7.52	-0.69 - 13.14

- The throw ratio is based on the value during projection with the projected image size of 3.81 m [150 in].
- Fine text and images may not be displayed clearly during projection with the projected image size over 15.24 m [600 in].

Screen aspect ratio 16:9

Unit: feet

Projector model				PT-REQ12/PT-REQ10/PT-REQ80 PT-REZ12/PT-REZ10/PT-REZ80		PT-REQ12/PT-REQ10/PT-REQ80 PT-REZ12/PT-REZ10/PT-REZ80
Throw ratio				0.308 - 0.331:1		
Projected image size				Projection distance (L)		Height position (H)
Diagonal (SD)		Height (SH)	Width (SW)	Min. (LW)	Max. (LT)	
m	inches					
2.54	100	4.09	7.26	2.20	2.36	-0.23 - 4.30
3.05	120	4.90	8.72	2.66	2.85	-0.26 - 5.18
3.81	150	6.13	10.90	3.35	3.61	-0.33 - 6.46
5.08	200	8.17	14.53	4.53	4.86	-0.46 - 8.63
6.35	250	10.21	18.16	5.68	6.07	-0.56 - 10.79
7.62	300	12.26	21.79	6.82	7.32	-0.69 - 12.93
8.89	350	14.30	25.42	7.97	8.56	-0.79 - 15.09
10.16	400	16.34	29.05	9.12	9.81	-0.92 - 17.26
12.70	500	20.43	36.32	11.45	12.27	-1.15 - 21.56
15.24	600	24.51	43.58	13.75	14.76	-1.38 - 25.89
17.78	700	28.60	50.84	16.08	17.26	-1.58 - 30.18
20.32	800	32.68	58.10	18.37	19.72	-1.80 - 34.51
22.86	900	36.77	65.37	20.70	22.21	-2.03 - 38.81
25.40	1000	40.86	72.63	23.00	24.67	-2.26 - 43.11

- The throw ratio is based on the value during projection with the projected image size of 3.81 m [150 in].
- Fine text and images may not be displayed clearly during projection with the projected image size over 15.24 m [600 in].

Screen aspect ratio 4:3

Unit: meters

Projector model				PT-REQ12/PT-REQ10/PT-REQ80 PT-REZ12/PT-REZ10/PT-REZ80		PT-REQ12/PT-REQ10/PT-REQ80 PT-REZ12/PT-REZ10/PT-REZ80
Throw ratio				0.371 - 0.398:1		
Projected image size				Projection distance (L)		Height position (H)
Diagonal (SD)		Height (SH)	Width (SW)	Min. (LW)	Max. (LT)	
m	inches					
2.54	100	1.524	2.032	0.74	0.80	0.00 - 1.52
3.05	120	1.829	2.438	0.90	0.96	0.00 - 1.83
3.81	150	2.286	3.048	1.13	1.21	0.00 - 2.29
5.08	200	3.048	4.064	1.52	1.63	0.00 - 3.05
6.35	250	3.810	5.080	1.91	2.05	0.00 - 3.81
7.62	300	4.572	6.096	2.29	2.46	0.00 - 4.57
8.89	350	5.334	7.112	2.68	2.88	0.00 - 5.33
10.16	400	6.096	8.128	3.07	3.29	0.00 - 6.10
12.70	500	7.620	10.160	3.85	4.13	0.00 - 7.62
15.24	600	9.144	12.192	4.62	4.96	0.00 - 9.14
17.78	700	10.668	14.224	5.40	5.79	0.00 - 10.67
20.32	800	12.192	16.256	6.18	6.62	0.00 - 12.19
22.86	900	13.716	18.288	6.95	7.46	0.00 - 13.72
25.40	1000	15.240	20.320	7.73	8.29	0.00 - 15.24

- The throw ratio is based on the value during projection with the projected image size of 3.81 m [150 in].
- Fine text and images may not be displayed clearly during projection with the projected image size over 15.24 m [600 in].

Screen aspect ratio 4:3

Unit: feet

Projector model				PT-REQ12/PT-REQ10/PT-REQ80 PT-REZ12/PT-REZ10/PT-REZ80		PT-REQ12/PT-REQ10/PT-REQ80 PT-REZ12/PT-REZ10/PT-REZ80
Throw ratio				0.371 - 0.398:1		
Projected image size				Projection distance (L)		Height position (H)
Diagonal (SD)		Height (SH)	Width (SW)	Min. (LW)	Max. (LT)	
m	inches					
2.54	100	5.00	6.67	2.43	2.63	0.00 - 4.99
3.05	120	6.00	8.00	2.95	3.15	0.00 - 6.00
3.81	150	7.50	10.00	3.71	3.97	0.00 - 7.51
5.08	200	10.00	13.33	4.99	5.35	0.00 - 10.01
6.35	250	12.50	16.67	6.27	6.73	0.00 - 12.50
7.62	300	15.00	20.00	7.51	8.07	0.00 - 14.99
8.89	350	17.50	23.33	8.79	9.45	0.00 - 17.49
10.16	400	20.00	26.67	10.07	10.79	0.00 - 20.01
12.70	500	25.00	33.33	12.63	13.55	0.00 - 25.00
15.24	600	30.00	40.00	15.16	16.27	0.00 - 29.99
17.78	700	35.00	46.67	17.72	19.00	0.00 - 35.01
20.32	800	40.00	53.33	20.28	21.72	0.00 - 39.99
22.86	900	45.00	60.00	22.80	24.48	0.00 - 45.01
25.40	1000	50.00	66.67	25.36	27.20	0.00 - 50.00

- The throw ratio is based on the value during projection with the projected image size of 3.81 m [150 in].
- Fine text and images may not be displayed clearly during projection with the projected image size over 15.24 m [600 in].

Calculation of the projection distance

To use a projected image size not listed in this manual, check the projected image size SD (m) and use the respective formula to calculate the value.

The unit of all the formulae is m. (Values obtained by the following calculation formulae contain a slight error.)
 When calculating the value using image size designation (value in inches), multiply the value in inches by 0.0254 and substitute it into SD in the formula.

Screen aspect ratio 16:10

Unit: m

Projector model	Projection distance (L) formula	
	Min. (LW)	Max. (LT)
PT-REQ12/PT-REQ10/PT-REQ80	= 0.2700 x SD - 0.0348	= 0.2895 x SD - 0.0353
PT-REZ12/PT-REZ10/PT-REZ80		

Screen aspect ratio 16:9

Unit: m

Projector model	Projection distance (L) formula	
	Min. (LW)	Max. (LT)
PT-REQ12/PT-REQ10/PT-REQ80	= 0.2775 x SD - 0.0348	= 0.2975 x SD - 0.0353
PT-REZ12/PT-REZ10/PT-REZ80		

Screen aspect ratio 4:3

Unit: m

Projector model	Projection distance (L) formula	
	Min. (LW)	Max. (LT)
PT-REQ12/PT-REQ10/PT-REQ80	= 0.3057 x SD - 0.0348	= 0.3277 x SD - 0.0353
PT-REZ12/PT-REZ10/PT-REZ80		

Adjustment range by the lens position shift (optical shift)

Based on the standard projection position using the optical axis shift function, the projection position can be adjusted in the range shown in the following figure.

Following figure shows the adjustment range when the projector is installed on the floor.

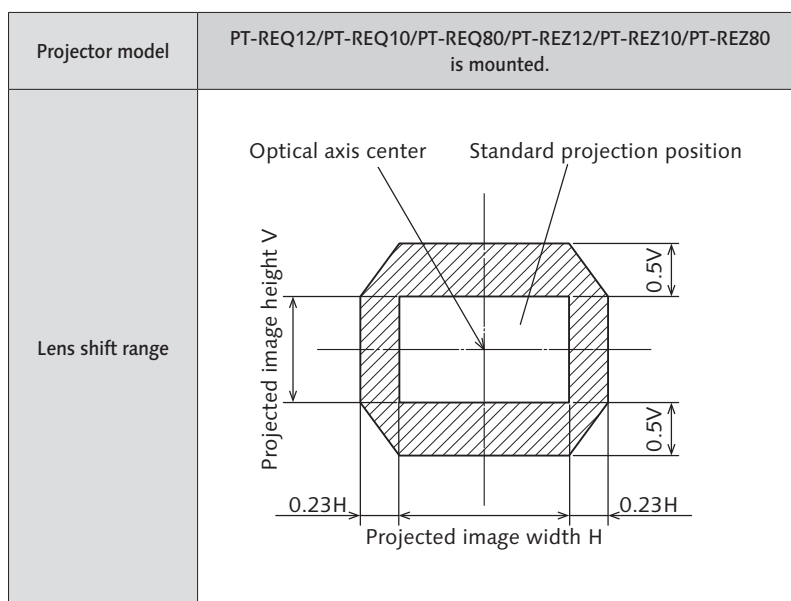

Note

- Return the projection lens to the home position before replacing or removing it.

[SCREEN ADJUSTMENT] projection range

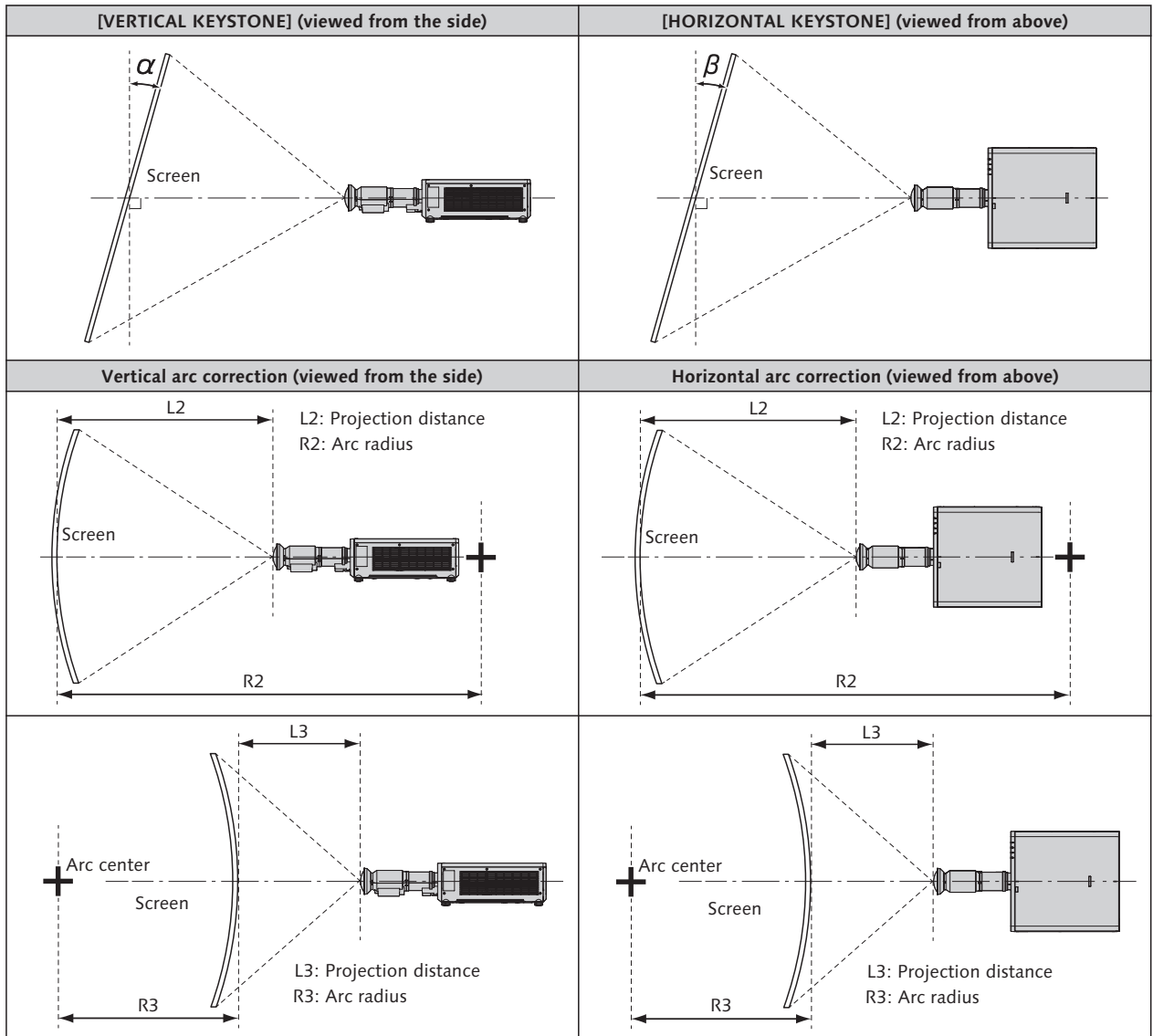

Projector model	Only [KEYSTONE] used		[KEYSTONE] and [CURVED CORRECTION] used together				Only [CURVED CORRECTION] used	
	Vertical keystone correction angle α (°)	Horizontal keystone correction angle β (°)	Vertical keystone correction angle α (°)	Horizontal keystone correction angle β (°)	Min. value of R2/L2	Min. value of R3/L3	Min. value of R2/L2	Min. value of R3/L3
PT-REQ12 PT-REQ10 PT-REQ80	±5	±3	-	-	-	-	-	-
PT-REZ12 PT-REZ10 PT-REZ80								