

## Fisheye Lens

**Description**

This Fisheye lens is designed for use with Panasonic's applicable projectors. The Fisheye Lens is ideal for projection to the dome screen.

**NOTE: The lens cannot be used by itself.  
It must be mounted onto the specified Panasonic projector (sold separately).**

**Specifications** (Specifications and appearance are subject to change for improvement without notice.)

Maximum angle of view	91.6° (Max Lens shift diagonal)
Projected angle	WQXGA H:61.3 V:38.4 D:72.3
	WUXGA H:65.7 V:41.1 D:77.5
	Full HD H:66.0 V:37.1 D:75.7
	SXGA+ H:60.7 V:45.5 D:75.9
	WXGA H:59.5 V:33.4 D:68.2
Lens shift:	WQXGA H:±17% V:±37%
	WUXGA H:±12% V:±27%
	Full HD H:±13% V:±35%
	SXGA+ H:±15% V:±25%
	WXGA H:±21% V:±54%
Focus adjustment function*1	yes
Optical masking*2	yes
Focal length(f):	9.0 mm
F value:	2.5
Auto Lens Identification function	Compatible models : PT-RQ45K/RZ44K/RQ35K2/RZ34K2/RQ35K/RZ34K/HTQ20/ RQ25K/RZ24K/RQ18K/RZ17K/RZ14K/RQ32K/RZ31K/RS30K/ RQ22K/RZ21K/RZ16K/RS20K
Dimensions:	Width 154 mm (6-1/16") (Excluding protrusions)
	Height 150 mm (5-29/32")
	Depth 529 mm (20-13/16")
Weight:	Approx 7.1 kg*3 (15.7 lbs*3)
Applicable projector*4:	[Group A] PT-DZ21K2/DS20K2/DW17K2/DZ16K2
	[Group B] PT-DZ13K/DS12K/DW11K/DZ10K
	[Group C] PT-RQ13K/RZ12K/RS11K
	[Group D] PT-RQ22K/RZ21K/RZ16K/RS20K
	[Group E] PT-RQ32K/RZ31K/RS30K
	----- PT-RQ45K/RZ44K/RQ35K2/RZ34K2/HTQ20/RQ35K/RZ34K/RQ25K/RZ24K/RQ18K/ RZ17K/RZ14K For these projectors see the individual spec files of the projectors

\*1 The focal balance between the center and periphery of the projected image changes depending on the size of the projected image. The lens is equipped with a focus balance adjustment function for the screen periphery.

\*2 Please contact your sales representative for further information.

\*3 Average value. May differ depending on the actual unit.

\*4 Models other than the above may also be supported. Refer to the operating instructions for your projector.

Fisheye Lens

Projection relationships

Dimensional relationship diagram

The dimensional relationship between the screen and the projector is shown below.

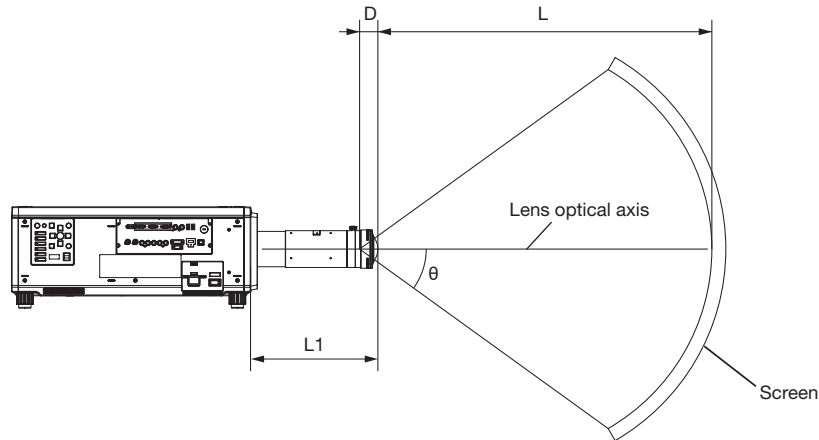

NOTE

- The indications of this illustration are premised on aligning the projected image size and position to the full screen.
- This illustration is not drawn to scale.

θ	Projected angle
L	Projection distance (lens front end to screen)
L1	Projector to lens front end
D	Exit pupil position

Model	L1 dimension (m)
PT-RQ32K/RZ31K/RS30K	0.355
PT-RQ22K/RZ21K/RZ16K/RS20K/ RQ13K/RZ12K/RS11K/ DZ21K2/DS20K2/DW17K2/ DZ16K2/DZ13K/DS12K/ DW11K/DZ10K	0.385

Projection distance (L) range (m)	2 to ∞
-----------------------------------	--------

Projected angle (θ) (degrees)	Exit pupil position (D) (m)*
10	0.0232
20	0.0229
30	0.0224
40	0.0216
50	0.0206
60	0.0191
70	0.0173
80	0.0150
91.6 (maximum)	0.0116

\* There may be slight discrepancies in the exit pupil positions.

Exit pupil position (D) formula	$D = -10^{-6} \times \theta^3 - 3 \times 10^{-7} \times \theta^2 - 1.73 \times 10^{-5} \times \theta + 0.02342$
---------------------------------	---

Fisheye Lens

Projected angle of view diagram

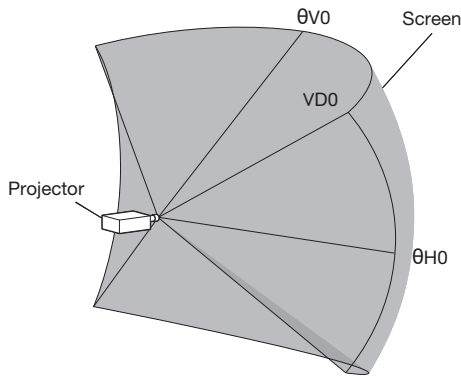

When the lens is centered

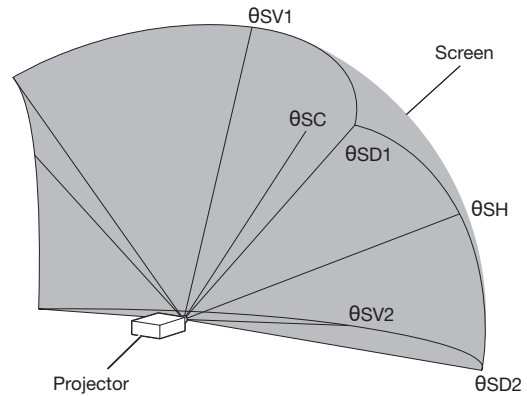

When the lens is shifted to the upward Vmax position

$\theta_{H0}$	Maximum horizontal center angle of view
$\theta_{V0}$	Maximum vertical center angle of view
$\theta_{D0}$	Maximum diagonal angle of view

$\theta_{SC}$	Center angle of view
$\theta_{SV1}$	Maximum vertical center angle of view
$\theta_{SV2}$	Maximum angle of view on opposing side of vertical center ( $\theta_{SV1}$ )
$\theta_{SH}$	Maximum horizontal center angle of view
$\theta_{SD1}$	Maximum diagonal angle of view
$\theta_{SD2}$	Maximum angle of view on vertically opposing side of diagonal ( $\theta_{SD1}$ )

OPT-RQ32K/RQ22K/RQ13K

$\theta_{H0}$	$\theta_{V0}$	$\theta_{D0}$
61.3	38.4	72.3

$\theta_{SC}$	$\theta_{SV1}$	$\theta_{SV2}$	$\theta_{SH}$	$\theta_{SD1}$	$\theta_{SD2}$
28.4	66.6	10.0	67.5	90.8	62.1

OPT-RZ31K/RZ21K/RZ16K/RZ12K/DZ21K2/DZ13K/DZ10K

$\theta_{H0}$	$\theta_{V0}$	$\theta_{D0}$
65.7	41.1	77.5

$\theta_{SC}$	$\theta_{SV1}$	$\theta_{SV2}$	$\theta_{SH}$	$\theta_{SD1}$	$\theta_{SD2}$
22.3	63.2	19.0	69.3	91.4	68.4

OPT-RS30K/RS20K/RS11K/DS20K2/DS12K

$\theta_{H0}$	$\theta_{V0}$	$\theta_{D0}$
60.7	45.5	75.9

$\theta_{SC}$	$\theta_{SV1}$	$\theta_{SV2}$	$\theta_{SH}$	$\theta_{SD1}$	$\theta_{SD2}$
22.8	68.3	22.8	64.8	91.5	64.8

OPT-DZ16K2

$\theta_{H0}$	$\theta_{V0}$	$\theta_{D0}$
66.0	37.1	75.7

$\theta_{SC}$	$\theta_{SV1}$	$\theta_{SV2}$	$\theta_{SH}$	$\theta_{SD1}$	$\theta_{SD2}$
26.0	63.1	11.1	70.9	91.3	66.9

OPT-DW17K2/DW11K

$\theta_{H0}$	$\theta_{V0}$	$\theta_{D0}$
59.5	33.4	68.2

$\theta_{SC}$	$\theta_{SV1}$	$\theta_{SV2}$	$\theta_{SH}$	$\theta_{SD1}$	$\theta_{SD2}$
36.1	69.6	2.7	69.6	91.5	59.5

NOTE

- The illustrations of projectors in this manual are for informational purposes only and do not represent a specific projector model. Configurations may vary with the model.
- As the front end of the lens approaches closer to a spherical or column-shaped screen center, uniformity of the total focus and total brightness of the projected image is enhanced.
- The angle of view values indicated in the tables are lens optical axis angles.

Fisheye Lens

Lens shift ranges

Lens shift function allows to shift the position of a projected image as shown below.

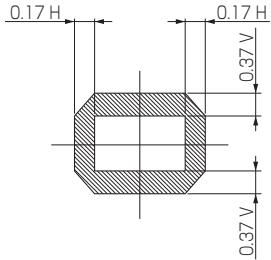
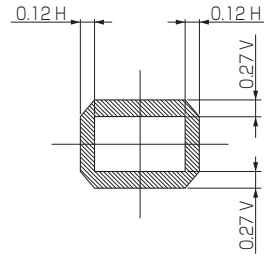
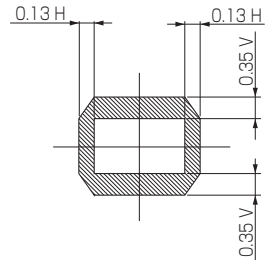
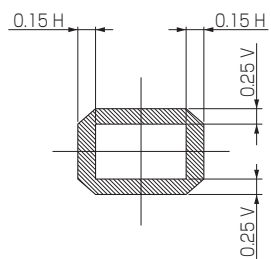
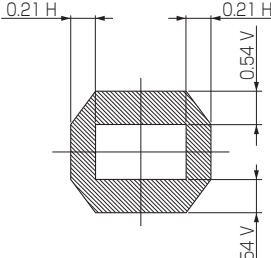
<p>PT-RQ32K / RQ22K / RQ13K</p>	
<p>PT-RZ31K / RZ16K / RZ21K / RZ12K / DZ21K2 / DZ13K / DZ10K</p>	
<p>PT-DZ16K2</p>	
<p>PT-RS30K / RS20K / RS11K / DS20K2 / DS12K</p>	
<p>PT-DW17K2 / DW11K</p>	

NOTE

- The lens shift ranges that are shown indicate the positional relationships between the projector's display panel (DLP chip) and lens. The screen position of the image projected on the screen does not move in proportion to the screen size. For details on the relationship between the lens shift and the projected angle of view, see "Projection relationships (P2)"

Dimensions

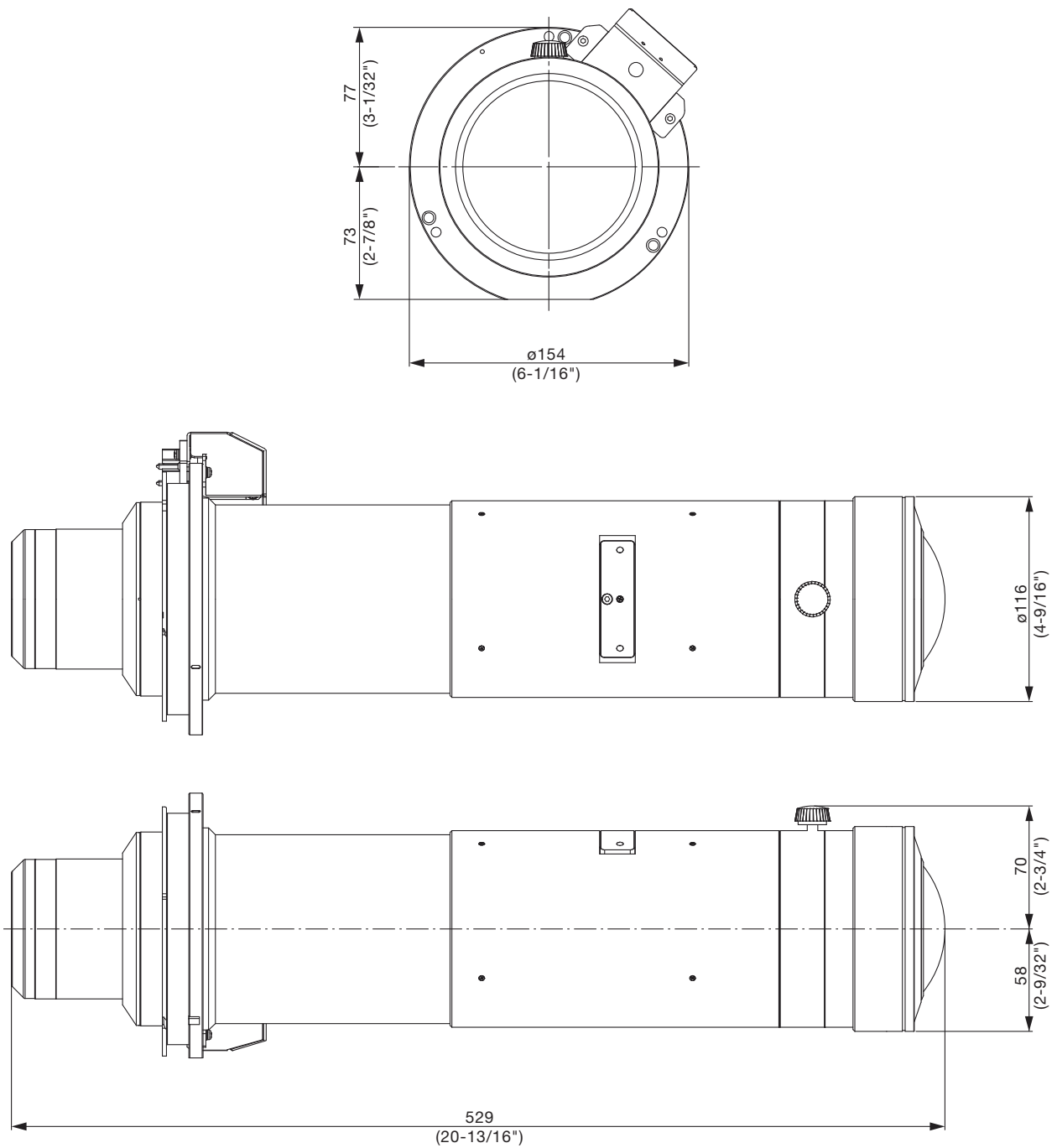

unit : mm (inch)  
 NOTE: This illustration is not drawn to scale.

[Group A]

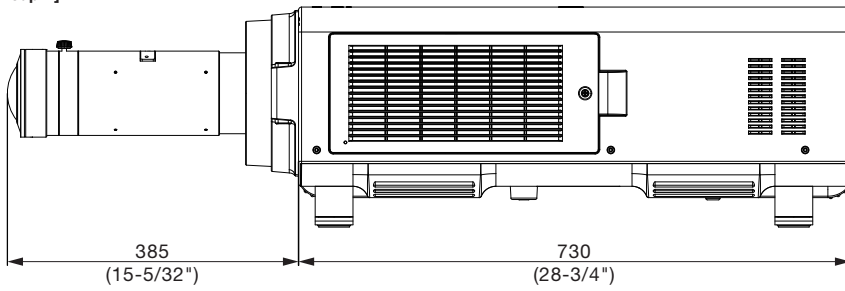

[Group B]

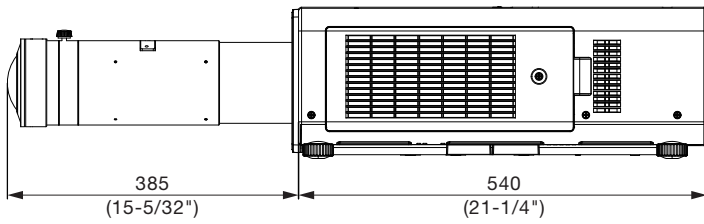

[Group C]

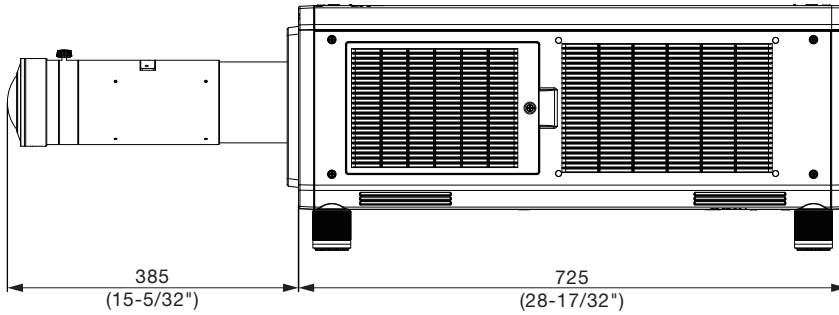

[Group D]

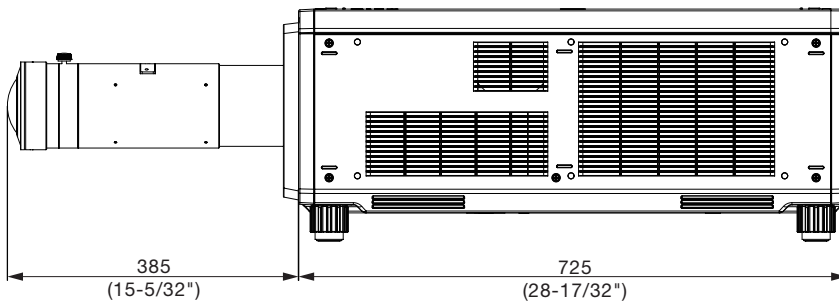

[Group E]

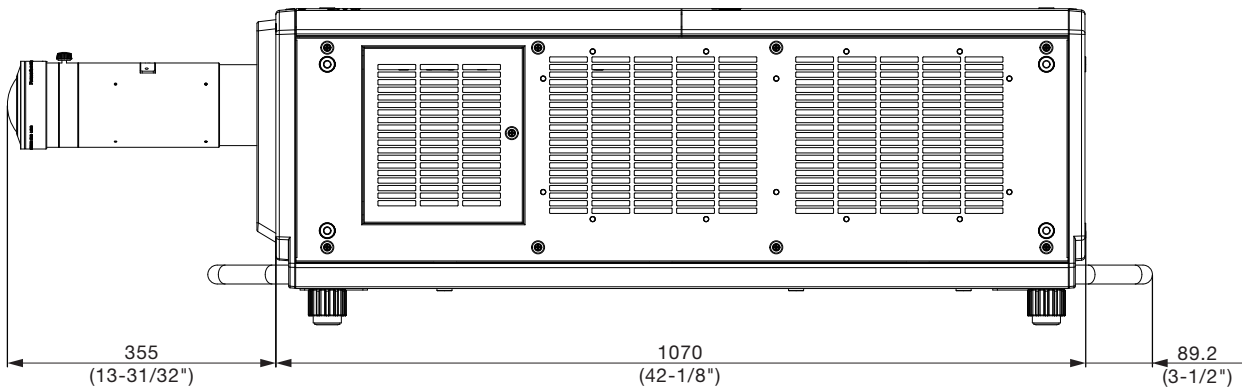

unit : mm (inch)  
NOTE: This illustration is not drawn to scale.