

Main unit

Power supply		AC100-240V, 50Hz/60Hz	
Power consumption ¹	Maximum power consumption		460 W (4.9A-2.1A) [485VA] (TBD) (The power consumption is 450 W at 200-240V)
	On-mode power consumption (Light power)	[NORMAL]	430 W (100-240 V), 420 W (200-240 V) (TBD)
		[ECO]	325 W (100-240 V), 315 W (200-240 V) (TBD)
		[QUIET1]	380 W (100-240 V), 370 W (200-240 V) (TBD)
	[QUIET2]	320 W (100-240 V), 315 W (200-240 V) (TBD)	
Standby mode power consumption	[NORMAL]	20 W (TBD)	
	[ECO]	0.5 W	
BTU value		Max 1,570 BTU (TBD)	
LCD panel	Size	16.3 mm [0.64 in] diagonal (16:10 aspect ratio)	
	Display system	Transparent LCD panel (x 3, R/G/B)	
	Number of pixels	2,304,000 (1920 x 1200) pixels	
Refresh rate		60 Hz Refresh rate varies depending on scanning frequency.	
Light source		Laser Diode	
Light output	Light Power	[NORMAL]	8,000 lm ¹ / 8,000 lm(ANSI) ² (TBD) [PICTURE MODE] is set to [DYNAMIC], [DAYLIGHT VIEW] is set to [OFF], [AUTO POWER SAVE] is set to [OFF]
		[ECO]	5,600 lm (TBD)
		[QUIET1]	6,800 lm (TBD)
		[QUIET2]	5,600 lm (TBD)
Time until light output declines to 50% ³	Light Power	[NORMAL]	20,000 hours
		[ECO]	24,000 hours
		[QUIET]	20,000 hours
Filter Replacement Cycle		20,000 hours (Under the dust conditions of 0.08mg/m ³) 10,000 hours (Under the dust conditions of 0.15 mg/m ³) Filter cleaning cycle varies depending on the environment. The filter can be washed and reused up to two times.	
Resolution		WUXGA (1920 x 1200dots)	
Contrast ratio ¹		3,000,000:1 (All White/All Black) When [PICTURE MODE] is set to [DYNAMIC], [DYNAMIC CONTRAST] is set to [1]	
Screen size		0.76-7.62 m [30-300 in], 16:10 aspect ratio	
Center to corner zone ratio ¹		85%	
Lens		1.6x Manual zoom (Optical) (Throw ratio 1.09-1.77:1) Manual focus lens, F=1.6-2.12, f=15.30-24.64 mm	
Digital Zoom Extender ⁴		Throw Ratio 1.09-2.21:1 ⁵ (Corresponding value) (When optical zoom is used together.)	
Lens shift (from the origin point of the lens mounter)	Vertical	+44%	
	Horizontal	±20%	
Installation		Ceiling/floor, front/rear, free 360-degree installation	
Maximum usable volume output		10W (monaural)	
Compatible Signal	RGB signal input	Resolution: 640 x 400 to 1920 x 1200 Dot clock frequency: 162 MHz or less PIAS (Panasonic Intelligent Auto Scanning) system	
	YCbCr/YPbPr signal input	Resolution: 480i/576i to 1920 x 1080 Dot clock frequency: 148.5 MHz or less The HD/SYNC and VD terminals do not support 3 value SYNC.	
	HDMI™ signal input	Moving image signal resolution: 480i ⁶ /576i ⁶ to 4096 x 2160 Still image signal resolution: 640 x 400 to 1920 x 1200 (non-interlace) Dot clock frequency: 25 MHz to 297 MHz	
	DIGITAL LINK signal input	Moving image signal resolution: 480i ⁶ /576i ⁶ to 4096 x 2160 Still image signal resolution: 640 x 400 to 1920 x 1200 (non-interlace) Dot clock frequency: 25 MHz to 297 MHz	
Terminals	<HDMI™ 1 IN> <HDMI™ 2 IN>	HDMI™-19 pin x 2 Deep Color, compatible with HDCP 1.4, 4K/30p signal input ⁷ , CEC supported ⁸ Audio Signal: Linear PCM (Sampling frequency: 48 kHz/44.1 kHz/32 kHz)	

Terminals	<COMPUTER IN>		D-sub 15 pin (female) x 1
		RGB	0.7 V [p-p], 75 ohms (1.0 V [p-p], 75 ohms for sync on G) HD/SYNC, VD: TTL, high impedance, positive/negative automatic
		YPbPr	Y: 1.0 V [p-p], including sync signal, Pb/Pr (Cb/Cr): 0.7 V [p-p], 75 ohms
	<AUDIO IN>		M3 stereo mini-jack x 1 0.5 V [rms], input Impedance 22 k Ohms and more
	<AUDIO OUT>		M3 stereo mini-jack x 1 0 V [rms] to 2.0 V [rms] variable, output Impedance 2.2 k ohms and less
	<SERIAL IN>		D-sub 9-pin (female) x 1 for computer control (RS-232C compliant)
	<LAN>		RJ-45 x 1 for network connection, PLink™ (Class 2), compatible with 10Base-T/100Base-TX
<DIGITAL LINK/LAN>		RJ-45 x 1 for network and DIGITAL LINK connection, HDBase-T™ compliant, 100Base-TX, compatible with PLink™ (Class 2), HDCP 1.4, Deep Color, 4K/30p signal input ⁷	
<USB (VIEWER/WIRELESS/DC OUT)>		USB connector (Type A) x 1 for Memory Viewer function, optional Wireless Module AJ-WM50, power supply (DC 5 V, maximum 2 A)	
Supported Internet protocol version			IPv4, IPv6 ⁹
Power cord length			2.0 m [6 ft 7 in] (3.0 m [9 ft 10 in] for India)
Cabinet materials			Molded plastic
Dimensions ¹⁰	Width		399 mm [15 23/32 in] (excluding protrusions)
			399 mm [15 23/32 in] (including protrusions)
	Height		115 mm [4 17/32 in] (excluding feet, protrusions)
			133 mm [5 1/4 in] (with the feet at shortest position, including protrusions)
Depth		348 mm [13 11/16 in] (excluding protrusions)	
		348 mm [13 11/16 in] (including protrusions)	
Weight ¹¹			Approx. 7.7 kg (16.15 lbs)
Operating noise ¹	[NORMAL]		39 dB
	[ECO]		39 dB
	[QUIET1]		34 dB
	[QUIET2]		29 dB
Laser Classification	Laser Class		Class 1 (IEC/EN 60825-1:2014)
	Risk Group		Risk Group 2 (IEC 62471-5:2015)
Operating environment	Operating environment temperature		0 °C (32 °F) to 45 °C (113 °F) ¹² *The operating environment temperature should be between 0 °C (32 °F) and 40 °C (104 °F) when the optional Wireless Module (Model No.: AJ-WM50 Series) is attached.
	Operating environment humidity		20% to 80% (no condensation)
Remote control unit			
Power supply			3V DC (AAA/R03/LR03 battery x 2)
Operation range			Approx. 30 m [98 ft 5 in] (when operated directly in front of signal receptor)
Dimensions	Width		48 mm [1 7/8 in]
	Height		145 mm [5 23/32 in]
	Depth		27 mm [1 1/16 in]
Weight ¹¹			Approx. 102 g (3.60 ozs.) including batteries

Supplied accessories

Power cord (x 2 for Europe and Asia model/ x 1 for other countries)
Wireless remote control unit (x 1)
Batteries for remote control (R03/AAA type x 2)
Lens cap (x 1)
Strap (x 1)

Other Applications

Multi Monitoring and Control Software (for Windows)
Presenter Light Software (for Windows)
Wireless Projector App (for iOS/Android™)

Optional accessories

Ceiling Mount Bracket	for high ceilings	ET-PKL100H
	for low ceilings	ET-PKL100S
	Attachment plate	ET-PKV400B
Replacement Filter Unit		ET-RFV500
DIGITAL LINK switcher		ET-YFB200G
Wireless Module		AJ-WM50 Note: The suffix at the end of the model number is omitted. Operating Temperature when attached to the projector: 0-40 °C (32-104 °F).
Wireless Presentation System (PressIT)		TY-WPS1 (basic set) Note: For further details, please visit the following website: https://docs.connect.panasonic.com/prodisplays/pressit/

Weights and dimensions shown are approximate. Specifications subject to change without notice.

- 1 Measurement, measuring conditions, and method of notation all comply with ISO/IEC 21118: 2020 international standards. Value is average of all products when shipped.
- 2 Measurement, measuring conditions, and method of notation all comply with American National Standards Institute standards. Value is the average of all products when shipped.
- 3 Around this time, light output will have decreased by approximately 50%. IEC62087: 2008 Broadcast contents, Dynamic Contrast [2], under conditions with 30 °C (86 °F), 700 m (2,297 ft) above sea level, and 0.15 mg/m³ of particulate matter. Panasonic recommends cleaning or checkup at point of purchase after about 20,000 hours. Light-source lifetime may be reduced depending on environmental conditions.
Replacement of parts other than the light source may be required in a shorter period. Estimated maintenance time varies depending on environment.
- 4 Resolution decreases when using this function. 6-Point Screen Correction, V/H Keystone Correction, and curved-screen correction are not available when using this function, and range of corner adjustment is limited.
- 5 When optical zoom is used together and Digital Zoom Extender is set to 80%.
- 6 Pixel-Repetition signal (dot clock frequency 27.0 MHz) only.
- 7 A signal with different resolution is converted to the number of display dots.
- 8 Depending on the connected CEC-compatible device, the link control may not operate normally.
- 9 Main version of the firmware must be 2.00 or higher. Optional wireless module AJ-WM50 does not support IPv6.
- 10 With legs at shortest position.
- 11 Average value. May differ depending on the actual unit.
- 12 Note that projector cannot be used at altitudes 2,700 m (8,858 ft) or higher above sea level. In the following operating environments, light output may be reduced to protect the projector; when the projector is used at altitudes below 700 m (2,297 ft) and ambient temperature is 36 °C (97 °F) or higher; when the projector is used at altitudes between 700 m (2,297 ft) and 1,400 m (4,593 ft) exclusive and ambient temperature is 34 °C (93 °F) or higher; when the projector is used at altitudes between 1,400 m (4,593 ft) and 2,100m (6,890 ft) exclusive and ambient temperature is 32 °C (90 °F) or higher; and when the projector is used at altitudes between 2,100 m (6,890 ft) and 2,700 m (8,858 ft) exclusive and ambient temperature is 30 °C (86 °F) or higher.

Terminals

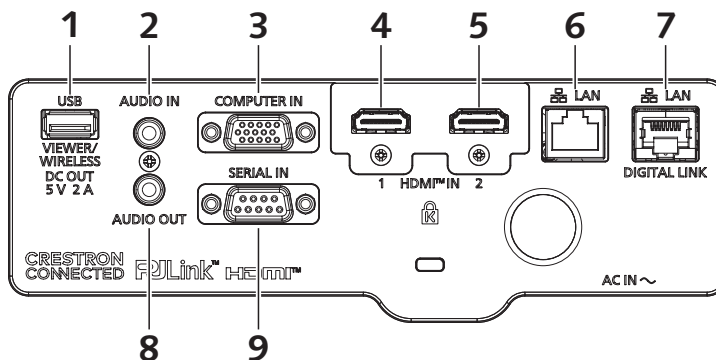

1	USB (VIEWER/WIRELESS/DC OUT)	6	LAN
2	AUDIO IN	7	DIGITAL LINK/LAN
3	COMPUTER IN	8	AUDIO OUT
4	HDMI™ 1 IN	9	SERIAL IN
5	HDMI™ 2 IN		

Dimensions

unit : mm [inch]
NOTE: This illustration is not drawn to scale.

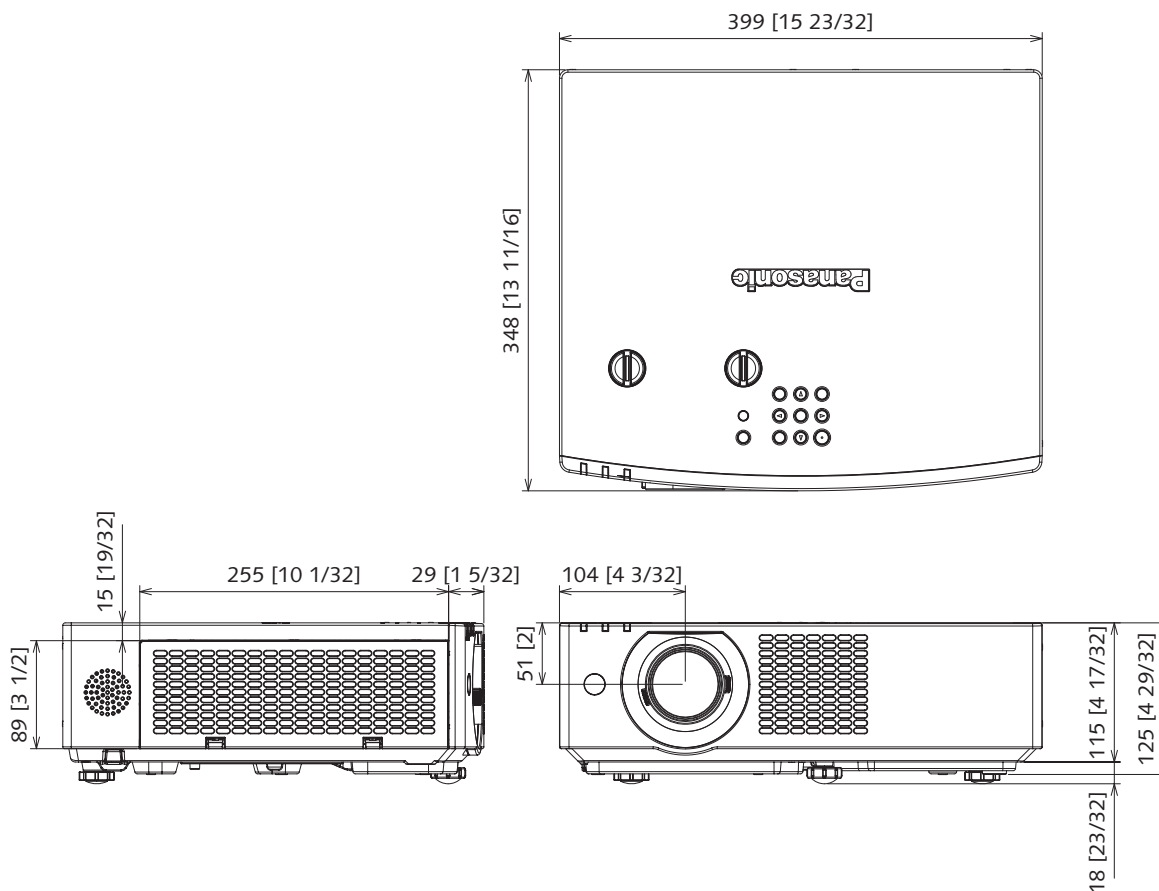

Projected image and throw distance

Install the projector referring to the projected image size and projection distance. Image size and image position can be adjusted in accordance with the screen size and screen position.

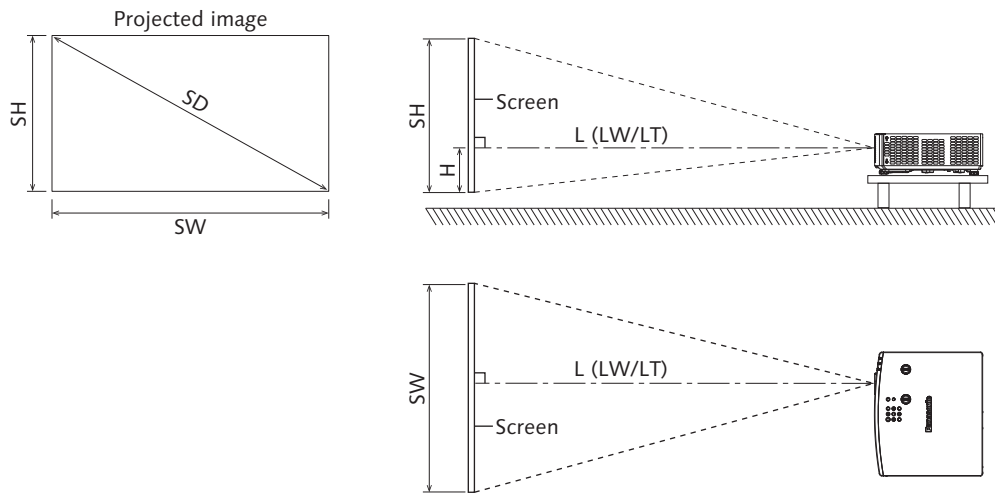

Note

- This illustration is prepared on the assumption that the projected image size and position have been aligned to fit full in the screen.
- This illustration is not drawn to scale.
- The values are approximate.

L		Projection distance
	LW	Minimum distance
	LT	Maximum distance
SH		Projected image height
SW		Projected image width
H		Distance from the lens center to the bottom edge of the projected image
SD		Projected image size

Standard setting position

Illustrations show the projector installed using optional ceiling mount bracket ET-PKL100H and projector mount bracket ET-PKV400B.

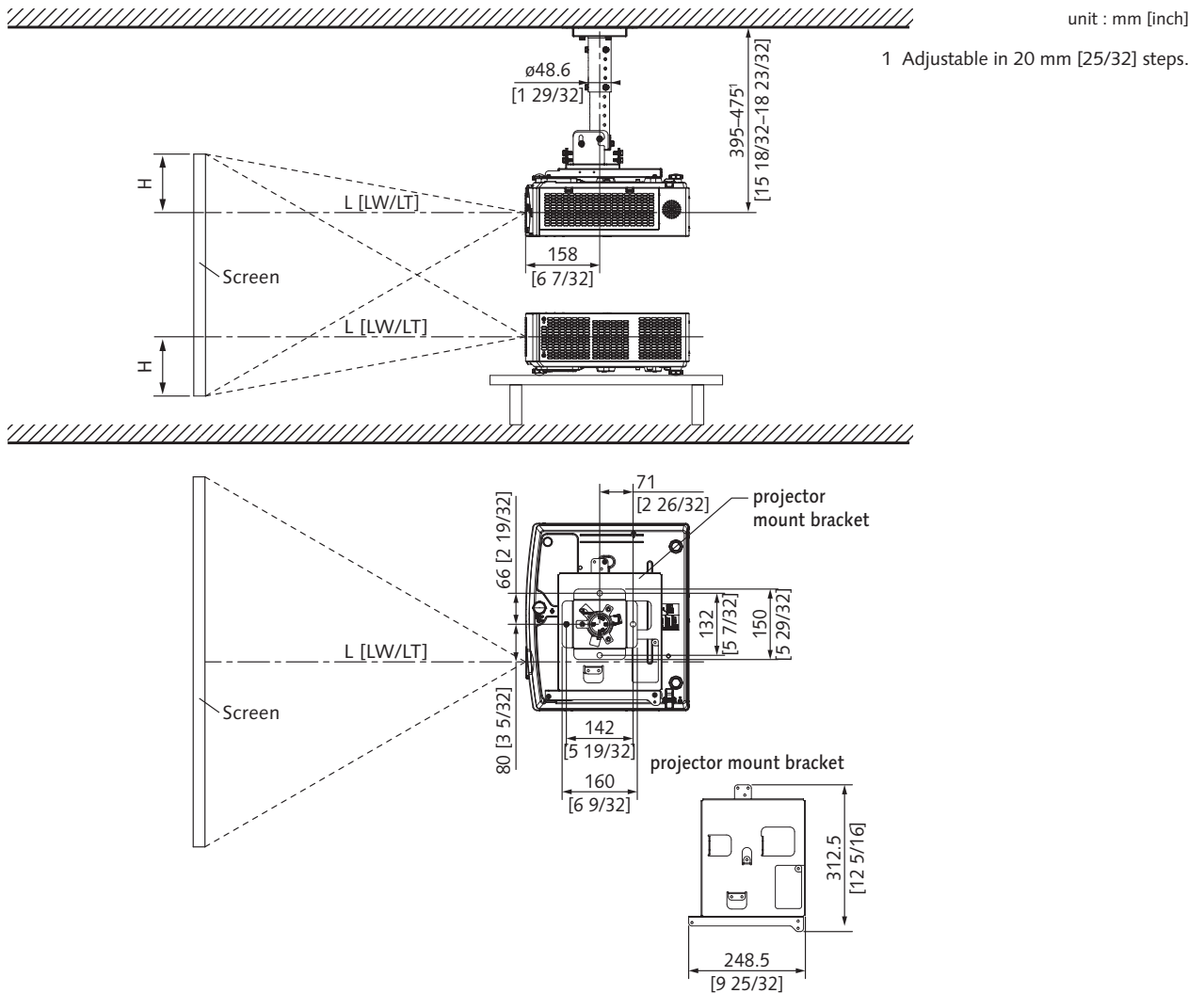

Caution

- All construction work should be done by a qualified technician.
- When mounting to the ceiling, use the special mounting bracket.
Furthermore, in order to prevent it from falling down from the ceiling, use the supplied wire on the mounting bracket.

Note

- This illustration is prepared on the assumption that the projected image size and position have been aligned to fit full in the screen.
- This illustration is not drawn to scale.
- The values are approximate.

Illustrations show the projector installed using optional ceiling mount bracket ET-PKL100S and projector mount bracket ET-PKV400B.

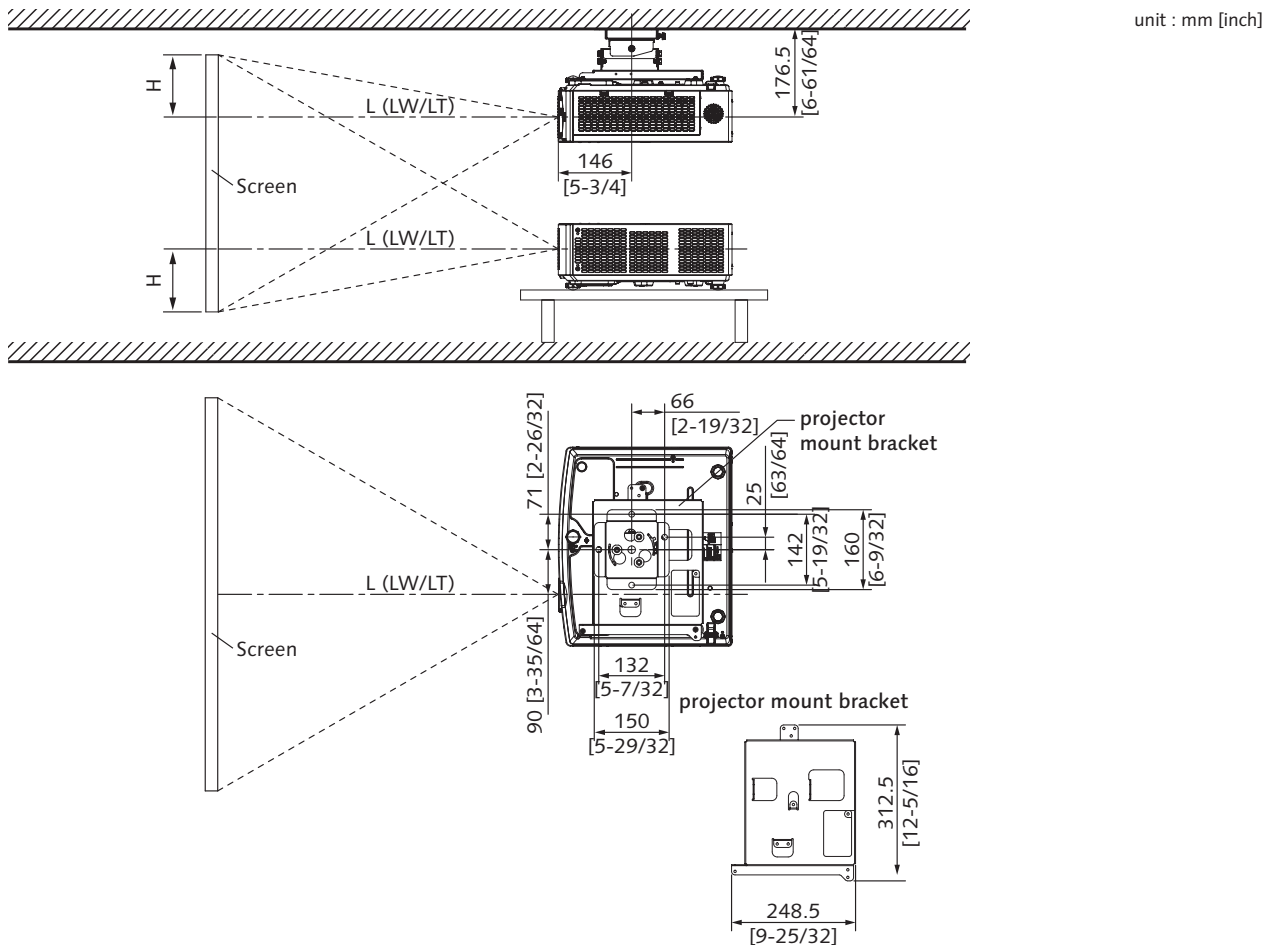
**Caution**

- All construction work should be done by a qualified technician.
- When mounting to the ceiling, use the special mounting bracket.
Furthermore, in order to prevent it from falling down from the ceiling, use the supplied wire on the mounting bracket.

Note

- This illustration is prepared on the assumption that the projected image size and position have been aligned to fit full in the screen.
- This illustration is not drawn to scale.
- The values are approximate.

Projection distance

A $\pm 5\%$ error in listed projection distances may occur. When [SCREEN ADJUSTMENT] is used, distance is corrected to become smaller than the specified image size.

Screen aspect ratio 16:10

Unit: meters

				Optical zoom		Digital Zoom Extender ¹	Height from the edge of screen to center of lens (H) ³
Throw ratio				1.31-2.12:1		1.31-2.66:1 ² (Corresponding Value)	
Projected image size				Projection distance (L)			
Diagonal (SD)		Height (SH)	Width (SW)	Min. (LW)	Max. (LT)	Max. (LT)	
m	inches						
0.76	30	0.40	0.64	0.68	1.12	1.40	0.022 - 0.201
1.02	40	0.54	0.86	0.93	1.51	1.89	0.030 - 0.270
1.27	50	0.67	1.08	1.16	1.89	2.37	0.037 - 0.337
1.52	60	0.81	1.29	1.39	2.26	2.84	0.045 - 0.403
1.78	70	0.94	1.51	1.64	2.66	3.33	0.052 - 0.472
2.03	80	1.08	1.72	1.87	3.03	3.80	0.060 - 0.538
2.29	90	1.21	1.94	2.12	3.43	4.29	0.067 - 0.607
2.54	100	1.35	2.15	2.35	3.80	4.76	0.075 - 0.673
3.05	120	1.62	2.59	2.83	4.57	5.73	0.090 - 0.808
3.81	150	2.02	3.23	3.54	5.72	7.16	0.112 - 1.010
5.08	200	2.69	4.31	4.73	7.64	9.56	0.150 - 1.346
6.35	250	3.37	5.38	5.92	9.56	11.96	0.187 - 1.683
7.62	300	4.04	6.46	7.11	11.48	14.35	0.224 - 2.019

- 1 The display resolution decreases when the Digital Zoom Extender function is used. In addition, the 6-point correction, keystone correction and curved correction functions cannot be used, and the adjustable range of corner correction is reduced.
- 2 When optical zoom is used together and Digital Zoom Extender is set to 80%.
- 3 Only for optical zoom

Unit: feet

				Optical zoom		Digital Zoom Extender ¹	Height from the edge of screen to center of lens (H) ³
Throw ratio				1.31-2.12:1		1.31-2.66:1 ² (Corresponding Value)	
Projected image size				Projection distance (L)			
Diagonal (SD)		Height (SH)	Width (SW)	Min. (LW)	Max. (LT)	Max. (LT)	
m	inches						
0.76	30	1.31	2.10	2.23	3.67	4.59	0.072 - 0.659
1.02	40	1.77	2.82	3.05	4.95	6.20	0.098 - 0.886
1.27	50	2.20	3.54	3.81	6.20	7.78	0.121 - 1.106
1.52	60	2.66	4.23	4.56	7.41	9.32	0.148 - 1.322
1.78	70	3.08	4.95	5.38	8.73	10.93	0.171 - 1.549
2.03	80	3.54	5.64	6.14	9.94	12.47	0.197 - 1.765
2.29	90	3.97	6.36	6.96	11.25	14.07	0.220 - 1.991
2.54	100	4.43	7.05	7.71	12.47	15.62	0.246 - 2.208
3.05	120	5.31	8.50	9.28	14.99	18.80	0.295 - 2.651
3.81	150	6.63	10.60	11.61	18.77	23.49	0.367 - 3.314
5.08	200	8.83	14.14	15.52	25.07	31.36	0.492 - 4.416
6.35	250	11.06	17.65	19.42	31.36	39.24	0.614 - 5.522
7.62	300	13.25	21.19	23.33	37.66	47.08	0.735 - 6.624

- 1 The display resolution decreases when the Digital Zoom Extender function is used. In addition, the 6-point correction, keystone correction and curved correction functions cannot be used, and the adjustable range of corner correction is reduced.
- 2 When optical zoom is used together and Digital Zoom Extender is set to 80%.
- 3 Only for optical zoom

Screen aspect ratio 16:9

Unit: meters

				Optical zoom		Digital Zoom Extender ¹	Height from the edge of screen to center of lens (H) ³
Throw ratio				1.31-2.12:1		1.31-2.66:1 ² (Corresponding Value)	
Projected image size				Projection distance (L)			
Diagonal (SD)		Height (SH)	Width (SW)	Min. (LW)	Max. (LT)	Max. (LT)	
m	inches						
0.76	30	0.37	0.66	0.70	1.15	1.44	0.002 - 0.186
1.02	40	0.50	0.89	0.95	1.55	1.95	0.003 - 0.250
1.27	50	0.62	1.11	1.19	1.94	2.43	0.004 - 0.311
1.52	60	0.74	1.33	1.43	2.33	2.92	0.005 - 0.372
1.78	70	0.87	1.55	1.69	2.73	3.42	0.005 - 0.436
2.03	80	0.99	1.77	1.93	3.12	3.91	0.006 - 0.497
2.29	90	1.12	2.00	2.18	3.52	4.41	0.007 - 0.561
2.54	100	1.24	2.21	2.42	3.91	4.90	0.008 - 0.622
3.05	120	1.49	2.66	2.91	4.70	5.89	0.009 - 0.747
3.81	150	1.87	3.32	3.64	5.88	7.36	0.012 - 0.933
5.08	200	2.49	4.43	4.86	7.85	9.83	0.015 - 1.245
6.35	250	3.11	5.54	6.09	9.83	12.29	0.019 - 1.556
7.62	300	3.73	6.64	7.31	11.80	14.75	0.023 - 1.867

- 1 The display resolution decreases when the Digital Zoom Extender function is used. In addition, the 6-point correction, keystone correction and curved correction functions cannot be used, and the adjustable range of corner correction is reduced.
- 2 When optical zoom is used together and Digital Zoom Extender is set to 80%.
- 3 Only for optical zoom

Unit: feet

				Optical zoom		Digital Zoom Extender ¹	Height from the edge of screen to center of lens (H) ³
Throw ratio				1.31-2.12:1		1.31-2.66:1 ² (Corresponding Value)	
Projected image size				Projection distance (L)			
Diagonal (SD)		Height (SH)	Width (SW)	Min. (LW)	Max. (LT)	Max. (LT)	
m	inches						
0.76	30	1.21	2.17	2.30	3.77	4.72	0.007 - 0.610
1.02	40	1.64	2.92	3.12	5.09	6.40	0.010 - 0.820
1.27	50	2.03	3.64	3.90	6.36	7.97	0.013 - 1.020
1.52	60	2.43	4.36	4.69	7.64	9.58	0.016 - 1.220
1.78	70	2.85	5.09	5.54	8.96	11.22	0.016 - 1.430
2.03	80	3.25	5.81	6.33	10.24	12.83	0.020 - 1.631
2.29	90	3.67	6.56	7.15	11.55	14.47	0.023 - 1.841
2.54	100	4.07	7.25	7.94	12.83	16.08	0.026 - 2.041
3.05	120	4.89	8.73	9.55	15.42	19.32	0.030 - 2.451
3.81	150	6.14	10.89	11.94	19.29	24.15	0.039 - 3.061
5.08	200	8.17	14.53	15.94	25.75	32.25	0.049 - 4.085
6.35	250	10.20	18.18	19.98	32.25	40.32	0.062 - 5.105
7.62	300	12.24	21.78	23.98	38.71	48.39	0.075 - 6.125

- 1 The display resolution decreases when the Digital Zoom Extender function is used. In addition, the 6-point correction, keystone correction and curved correction functions cannot be used, and the adjustable range of corner correction is reduced.
- 2 When optical zoom is used together and Digital Zoom Extender is set to 80%.
- 3 Only for optical zoom

Screen aspect ratio 4:3

Unit: meters

				Optical zoom		Digital Zoom Extender ¹	Height from the edge of screen to center of lens (H) ³
Throw ratio				1.31-2.12:1		1.31-2.66:1 ² (Corresponding Value)	
Projected image size				Projection distance (L)			
Diagonal (SD)		Height (SH)	Width (SW)	Min. (LW)	Max. (LT)	Max. (LT)	
m	inches						
0.76	30	0.46	0.61	0.78	1.27	1.59	0.025 - 0.228
1.02	40	0.61	0.82	1.05	1.71	2.15	0.034 - 0.306
1.27	50	0.76	1.02	1.32	2.14	2.68	0.042 - 0.381
1.52	60	0.91	1.22	1.58	2.57	3.22	0.051 - 0.456
1.78	70	1.07	1.42	1.86	3.01	3.77	0.059 - 0.534
2.03	80	1.22	1.62	2.12	3.44	4.31	0.068 - 0.609
2.29	90	1.37	1.83	2.40	3.88	4.86	0.076 - 0.687
2.54	100	1.52	2.03	2.67	4.31	5.40	0.085 - 0.762
3.05	120	1.83	2.44	3.21	5.18	6.49	0.102 - 0.915
3.81	150	2.29	3.05	4.01	6.48	8.11	0.127 - 1.143
5.08	200	3.05	4.06	5.36	8.65	10.83	0.169 - 1.524
6.35	250	3.81	5.08	6.71	10.83	13.54	0.212 - 1.905
7.62	300	4.57	6.10	8.05	13.00	16.25	0.254 - 2.286

- 1 The display resolution decreases when the Digital Zoom Extender function is used. In addition, the 6-point correction, keystone correction and curved correction functions cannot be used, and the adjustable range of corner correction is reduced.
- 2 When optical zoom is used together and Digital Zoom Extender is set to 80%.
- 3 Only for optical zoom

Unit: feet

				Optical zoom		Digital Zoom Extender ¹	Height from the edge of screen to center of lens (H) ³
Throw ratio				1.31-2.12:1		1.31-2.66:1 ² (Corresponding Value)	
Projected image size				Projection distance (L)			
Diagonal (SD)		Height (SH)	Width (SW)	Min. (LW)	Max. (LT)	Max. (LT)	
m	inches						
0.76	30	1.51	2.00	2.56	4.17	5.22	0.082 - 0.748
1.02	40	2.00	2.69	3.44	5.61	7.05	0.112 - 1.004
1.27	50	2.49	3.35	4.33	7.02	8.79	0.138 - 1.250
1.52	60	2.99	4.00	5.18	8.43	10.56	0.167 - 1.496
1.78	70	3.51	4.66	6.10	9.88	12.37	0.194 - 1.752
2.03	80	4.00	5.31	6.96	11.29	14.14	0.223 - 1.998
2.29	90	4.49	6.00	7.87	12.73	15.94	0.249 - 2.254
2.54	100	4.99	6.66	8.76	14.14	17.72	0.279 - 2.500
3.05	120	6.00	8.01	10.53	16.99	21.29	0.335 - 3.002
3.81	150	7.51	10.01	13.16	21.26	26.61	0.417 - 3.750
5.08	200	10.01	13.32	17.59	28.38	35.53	0.554 - 5.000
6.35	250	12.50	16.67	22.01	35.53	44.42	0.696 - 6.250
7.62	300	14.99	20.01	26.41	42.65	53.31	0.833 - 7.500

- 1 The display resolution decreases when the Digital Zoom Extender function is used. In addition, the 6-point correction, keystone correction and curved correction functions cannot be used, and the adjustable range of corner correction is reduced.
- 2 When optical zoom is used together and Digital Zoom Extender is set to 80%.
- 3 Only for optical zoom

Formula for calculating the projection distance

To use a projected image size not listed in this manual, check the projected image size SD (m) and use the respective formula to calculate the value.

The unit of all the formulae is m. (Values obtained by the following calculation formulae contain a slight error.)

When calculating the value using image size designation (value in inches), multiply the value in inches by 0.0254 and substitute it into SD in the formula.

Unit: m

Aspect ratio		16:10	16:9	4:3	
Screen height (SH)		= 0.530 x SD	= 0.490 x SD	= 0.6 x SD	
Screen width (SW)		= 0.848 x SD	= 0.872 x SD	= 0.8 x SD	
Projection distance (L)	Optical zoom	Min. (LW)	= 0.9371 x SD - 0.0294	= 0.9632 x SD - 0.0294	= 1.0609 x SD - 0.0294
		Max. (LT)	= 1.5103 x SD - 0.0319	= 1.5523 x SD - 0.0319	= 1.7098 x SD - 0.0319
	Digital Zoom Extender	Min. (LW)	= 0.9371 x SD / X - 0.0294	= 0.9632 x SD / X - 0.0294	= 1.0609 x SD / X - 0.0294
		Max. (LT)	= 1.5103 x SD / X - 0.0319	= 1.5523 x SD / X - 0.0319	= 1.7098 x SD / X - 0.0319

* X in the formulas represents the setting value of [DIGITAL ZOOM EXTENDER] (100%=1.00, 95%=0.95, 90%=0.90, 85%=0.85, 80%=0.80).

Note

- The value for L (distance to screen) varies slightly within $\pm 5\%$ depending on the zoom lens characteristics.
- When keystone correction is used, the image is corrected in the direction that reduces its projected size.

Adjustment range by the lens position shift (optical shift)

The projector supports lens shift in horizontal and vertical direction. The following figure shows the lens shift adjustable range in horizontal and vertical direction with reference to the standard projection position.

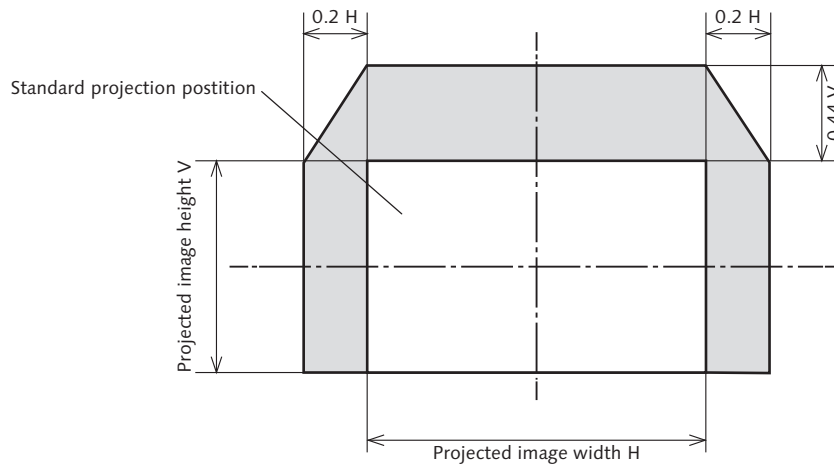

Note

- The standard projection position indicates the projection screen position in the state without lens shift adjustment.

[SCREEN ADJUSTMENT] projection range

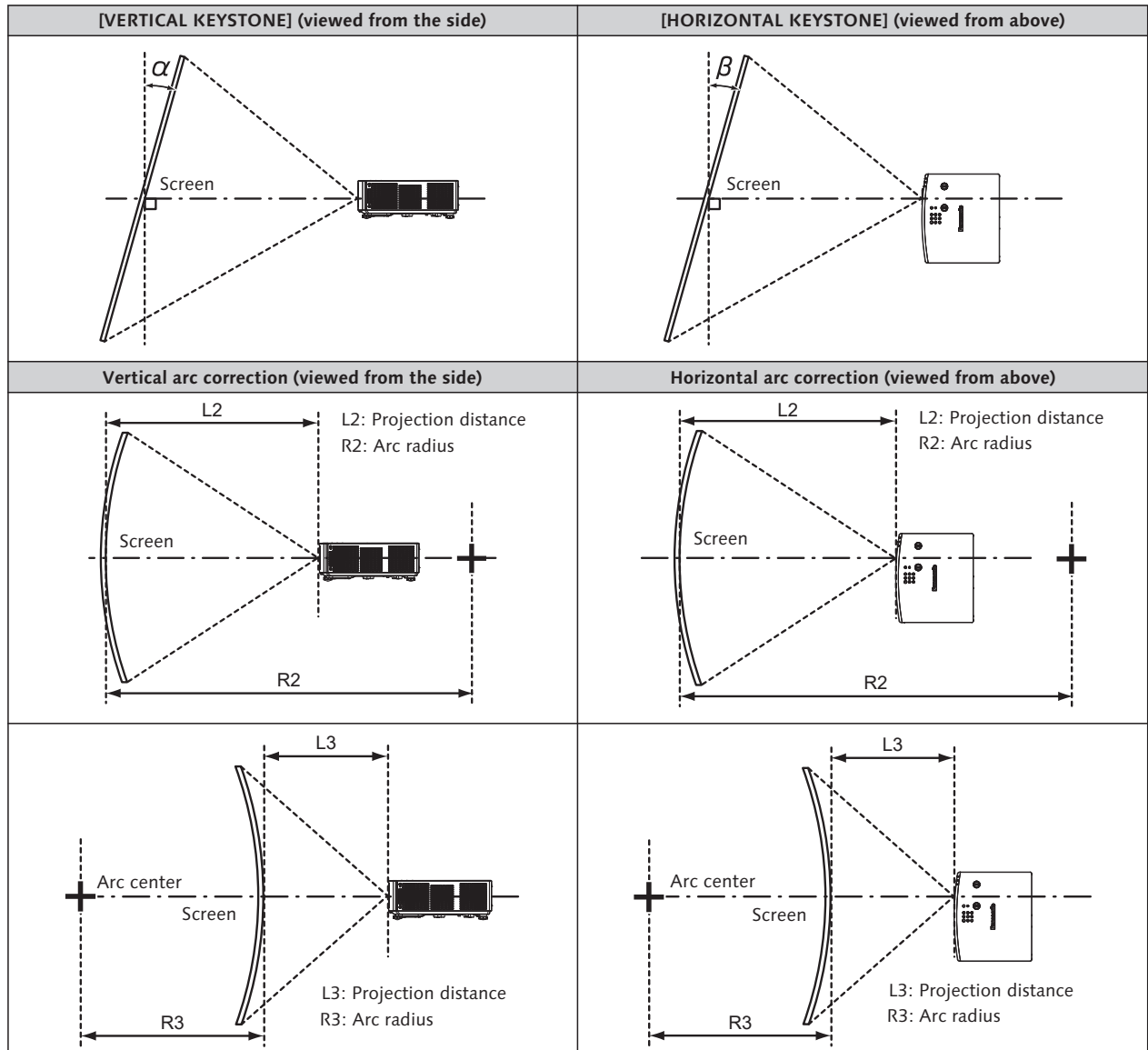

Model No.	Only [KEYSTONE] used		[KEYSTONE] and [CURVED CORRECTION] used together				Only [CURVED CORRECTION] used	
	Vertical keystone correction angle α (°)	Horizontal keystone correction angle β (°)	Vertical keystone correction angle α (°)	Horizontal keystone correction angle β (°)	Min. value of R2/L2	Min. value of R3/L3	Min. value of R2/L2	Min. value of R3/L3
PT-VMZ82	±25	±35	±25	±35	1.4	2.9	0.7	1.6

Note

- When [SCREEN ADJUSTMENT] is used, the focus of the entire screen may be lost as correction increases.
- Make the curved screen a circular arc shape with one part of a perfect circle removed.

Installable angle

Install the projector at an angle within the range shown below.

FULL 360-degree projection

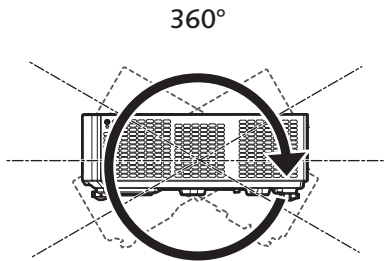

Vertical 360-deg.

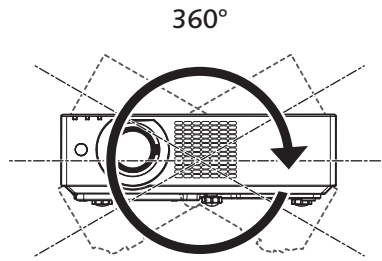

Horizontal 360-deg.

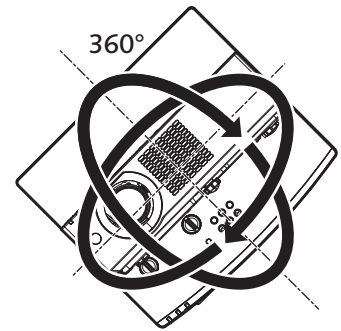

Tilting 360-deg.
(Vertical and Horizontal combination)

Notes on projector placement and operation

- Do not stack projectors on top of each other.
- Do not use the projector supporting it by the top.
- Do not block the intake/exhaust vents of the projector.
- Prevent hot and cool air from the air conditioning system to blow directly to the intake/exhaust vents of the projector.
- Do not install the projector in a confined space.

When installing the projector in a confined space, provide air conditioning or ventilation separately.

Exhaust heat may accumulate when the ventilation is not enough, triggering the protection circuit of the projector.

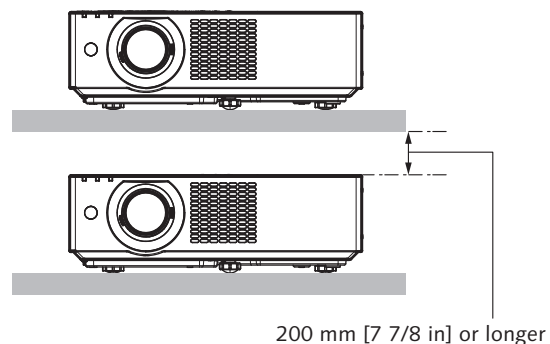
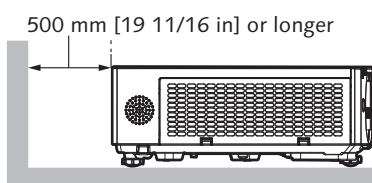
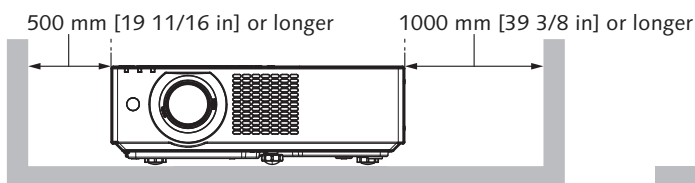
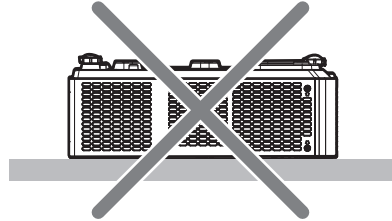
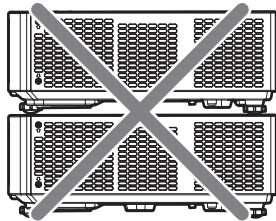

- When installing and fixing the projector on a ceiling or wall using a mount, make sure that the fixing screw or power cord does not come in contact with the metal section inside the ceiling or wall. Failure to observe this may result in electric shocks.
- Panasonic Connect Co., Ltd. takes no responsibility for any damage to the product caused by an inappropriate choice of location for installing the projector, even if the warranty period of the product has not expired.
- Immediately remove the product that is not in use anymore by asking a qualified technician.

List of compatible signals

The following table specifies the type of signals compatible with the projector.

- The content of the compatible signal column is as follows.
 - V: Video signal
 - C: Computer signal
- Symbols that indicate formats are as follows.
 - R: RGB
 - Y: YC_BC_R/YP_BP_R
 - H: HDMI™/DIGITAL LINK
- Input corresponding to each item in the plug and play column is as follows.
 - COMPUTER: COMPUTER input
 - HDMI™: HDMI™ 1/ HDMI™ 2 input
 - DIGITAL LINK: DIGITAL LINK input

Signal type	Signal name	Resolution (Dots)	Scanning freq.		Dot clock freq. (MHz)	Format	Plug and play correspondence ¹	
			Horizontal (kHz)	Vertical (Hz)			COMPUTER	HDMI™/DIGITAL LINK
V	480 /60i	720 x 480i	15.7	59.9	13.5	R/Y	–	–
	576 /50i	720 x 576i	15.6	50.0	13.5	R/Y	–	–
	480 /60i	720(1440) x 480i ²	15.7	59.9	27.0	H	–	–
	576 /50i	720(1440) x 576i ²	15.6	50.0	27.0	H	–	–
	480 /60p	720 x 480	31.5	59.9	27.0	R/Y/H	–	✓
	576 /50p	720 x 576	31.3	50.0	27.0	R/Y/H	–	✓
	720 /60p	1280 x 720	45.0	60.0 ³	74.3	R/Y/H	–	✓
	720 /50p	1280 x 720	37.5	50.0	74.3	R/Y/H	–	✓
	1080 /60i	1920 x 1080i	33.8	60.0 ³	74.3	R/Y/H	–	✓
	1080 /50i	1920 x 1080i	28.1	50.0	74.3	R/Y/H	–	✓
	1080 /24p	1920 x 1080	27.0	24.0 ³	74.3	R/Y/H	–	✓
	1080 /24sF	1920 x 1080i	27.0	48.0 ³	74.3	R/Y/H	–	–
	1080 /25p	1920 x 1080	28.1	25.0	74.3	R/Y/H	–	–
	1080 /30p	1920 x 1080	33.8	30.0 ³	74.3	R/Y/H	–	–
	1080 /60p	1920 x 1080	67.5	60.0 ³	148.5	R/Y/H	–	✓
	1080 /50p	1920 x 1080	56.3	50.0	148.5	R/Y/H	–	✓
	3840 x 2160/24p	3840 x 2160	54.0	24.0 ³	297.0	H	–	✓
	3840 x 2160/25p	3840 x 2160	56.3	25.0	297.0	H	–	✓
	3840 x 2160/30p	3840 x 2160	67.5	30.0 ³	297.0	H	–	✓
	4096 x 2160/24p	4096 x 2160	54.0	24.0 ³	297.0	H	–	✓
4096 x 2160/25p	4096 x 2160	56.3	25.0	297.0	H	–	✓	
4096 x 2160/30p	4096 x 2160	67.5	30.0 ³	297.0	H	–	✓	
C	640 x 400/70	640 x 400	31.5	70.1	25.2	R/H	–	–
	640 x 400/85	640 x 400	37.9	85.1	31.5	R/H	–	–
	640 x 480/60	640 x 480	31.5	59.9	25.2	R/H	✓	✓
	640 x 480/67	640 x 480	35.0	66.7	30.2	R/H	–	–
	640 x 480/73	640 x 480	37.9	72.8	31.5	R/H	✓	✓
	640 x 480/75	640 x 480	37.5	75.0	31.5	R/H	✓	✓
	640 x 480/85	640 x 480	43.3	85.0	36.0	R/H	–	–
	800 x 600/56	800 x 600	35.2	56.3	36.0	R/H	✓	✓
	800 x 600/60	800 x 600	37.9	60.3	40.0	R/H	✓	✓
	800 x 600/72	800 x 600	48.1	72.2	50.0	R/H	✓	✓
	800 x 600/75	800 x 600	46.9	75.0	49.5	R/H	✓	✓
	800 x 600/85	800 x 600	53.7	85.1	56.3	R/H	–	–
	832 x 624/75	832 x 624	49.7	74.6	57.3	R/H	✓	✓
	1024 x 768/504	1024 x 768	39.6	50.0	51.9	R/H	–	–
	1024 x 768/60	1024 x 768	48.4	60.0	65.0	R/H	✓	✓
	1024 x 768/70	1024 x 768	56.5	70.1	75.0	R/H	✓	✓
	1024 x 768/75	1024 x 768	60.0	75.0	78.8	R/H	✓	✓
	1024 x 768/82	1024 x 768	65.5	81.6	86.0	R/H	–	–
	1024 x 768/85	1024 x 768	68.7	85.0	94.5	R/H	–	–
	1024 x 768/100	1024 x 768	81.4	100.0	113.3	R/H	–	–
1152 x 864/60	1152 x 864	53.7	60.0	81.6	R/H	–	–	
1152 x 864/75	1152 x 864	67.5	75.0	108.0	R/H	–	–	
1152 x 864/85	1152 x 864	77.1	85.0	119.7	R/H	–	–	
1152 x 870/75	1152 x 870	68.7	75.1	100.0	R/H	✓	✓	

Signal type	Signal name	Resolution (Dots)	Scanning freq.		Dot clock freq. (MHz)	Format	Plug and play correspondence ¹	
			Horizontal (kHz)	Vertical (Hz)			COMPUTER	HDMI™/DIGITAL LINK
C	1280 x 720/50	1280 x 720	37.1	49.8	60.5	R/H	–	–
	1280 x 720/60	1280 x 720	44.8	59.9	74.5	R/H	–	–
	1280 x 768/604	1280 x 768	47.7	60.0	80.1	R/H	–	–
	1280 x 768/60	1280 x 768	47.8	59.9	79.5	R/H	–	–
	1280 x 768/75	1280 x 768	60.3	74.9	102.3	R/H	–	–
	1280 x 768/85	1280 x 768	68.6	84.8	117.5	R/H	–	–
	1280 x 800/50	1280 x 800	41.3	50.0	68.0	R/H	–	–
	1280 x 800/60	1280 x 800	49.7	59.8	83.5	R/H	–	–
	1280 x 800/75	1280 x 800	62.8	74.9	106.5	R/H	–	–
	1280 x 800/85	1280 x 800	71.6	84.9	122.5	R/H	–	–
	1280 x 960/60	1280 x 960	60.0	60.0	108.0	R/H	–	–
	1280 x 1024/604	1280 x 1024	64.0	60.0	108.0	R/H	–	–
	1280 x 1024/75	1280 x 1024	80.0	75.0	135.0	R/H	✓	✓
	1280 x 1024/85	1280 x 1024	91.1	85.0	157.5	R/H	–	–
	1366 x 768/50	1366 x 768	39.6	49.9	69.0	R/H	–	–
	1366 x 768/60	1366 x 768	47.7	59.8	85.5	R/H	–	–
	1366 x 768/604	1366 x 768	47.7	60.0	84.7	R/H	–	–
	1400 x 1050/60	1400 x 1050	65.3	60.0	121.8	R/H	–	–
	1400 x 1050/604	1400 x 1050	65.2	60.0	122.6	R/H	–	–
	1400 x 1050/75	1400 x 1050	82.2	75.0	155.9	R/H	–	–
	1440 x 900/504	1440 x 900	46.3	50.0	87.4	R/H	–	–
	1440 x 900/604	1440 x 900	55.9	60.0	106.5	R/H	–	–
	1440 x 900/60	1440 x 900	55.9	59.9	106.5	R/H	–	–
	1600 x 900/504	1600 x 900	46.3	50.0	97.0	R/H	–	–
	1600 x 900/604	1600 x 900	55.9	60.0	119.0	R/H	–	–
	1600 x 1200/60	1600 x 1200	75.0	60.0	162.0	R/H	✓	✓
	1680 x 1050/50	1680 x 1050	54.1	50.0	119.5	R/H	–	–
	1680 x 1050/60	1680 x 1050	65.3	60.0	146.3	R/H	–	–
	1680 x 1050/604	1680 x 1050	65.2	60.0	147.1	R/H	–	–
	1920 x 1080/50	1920 x 1080	55.6	49.9	141.5	R/H	–	–
1920 x 1080/605	1920 x 1080	66.6	59.9	138.5	R/H	–	–	
1920 x 1200/50	1920 x 1200	61.8	49.9	158.3	R/H	–	–	
1920 x 1200/605	1920 x 1200	74.0	60.0	154.0	R/H	✓	✓	

- Signal with ✓ in the plug and play column is a signal described in the EDID (extended display identification data) of the projector. The signal that does not have ✓ in the plug and play column can also be input if it is described in the format column. The resolution may not be selected in the computer even if the projector is compatible with the signal that does not have ✓ in the plug and play column.
- Pixel-Repetition signal (dot clock frequency 27.0 MHz) only
- It also supports signals with vertical scanning frequency of 1 / 1.001 times.
- When inputting appropriate analog signal, it can be displayed by making the setting suitable for the signal from the [PICTURE] menu → [RGB-SYSTEM]. For digital signal, the [RGB-SYSTEM] setting is unnecessary.
- VESA CVT-RB (Reduced Blanking)-compliant

Note

- A signal with a different resolution is converted to the number of display dots.
1920 x 1200
- The "i" at the end of the resolution indicates an interlaced signal.
- When interlaced signals are connected, flickering may occur on the projected image.
- The maximum transmission distance when connected with the long-reach communication method is 150 m [492 ft 2 in]. In this case, the signal that the projector can receive is only up to 1080/60p (1920 x 1080 dots, dot clock frequency 148.5 MHz).
- Even the above signals exist, some image signals recorded in special method may not be displayed.