





TOUGHBOOK 33 2-IN-1 DETACHABLE WINDOWS 11 PRO 12" FULLY RUGGED NOTEBOOK

TOUGHBOOK 33 2-in-1 Detachable, 12.0" fully rugged notebook with hot swappable twin batteries, detachable keyboard with optional backlit keys, and highly configurable capabilities brings unrivalled flexibility and performance for mobile business computing. Thanks to the detachable keyboard design and 6 usage modes, the TOUGHBOOK 33 2-in-1 Detachable offers the best of all worlds for mobile workers. Target industries for the device include field service workers, maintenance and service technicians in utilities and telecommunications, as well as government agencies, defence, the police and other emergency services.

- Intel® Core™ i5-1345U vPro™ processor
- Windows 11 Pro
- Next generation Dual-touch (with digitiser) display with 3:2 aspect ratio
- 12.0" QHD (2160 × 1440) anti-reflective high brightness outdoor display (up to 1200cd/m²)
- Capacitive 10 finger multi-touchscreen with glove and rain modes
- Digitiser pen embedded in the tablet part
- Detachable keyboard with various enterprise ports and backlit* keys
- Fully rugged design with water and dust resistance (IP65)**
- User exchangeable and hot-swappable twin batteries
- Flexible configuration port*** and business expansion module***
- Vehicle mount* available for both notebook and tablet

*Optional

**Tested at Panasonic factory and does not guarantee against damage or malfunction

***One option exclusively possible in configuration port / business expansion module

All technical specifications are subject to change without notice.





TOUGHBOOK 33 TABLET

WINDOWS 11 PRO 12" FULLY RUGGED TABLET

TOUGHBOOK 33 Tablet, the 12.0" fully rugged device with hot swappable twin batteries and highly configurable capabilities brings unrivalled flexibility and performance for mobile business computing. Thanks to the optional detachable keyboard, the TOUGHBOOK 33 Tablet offers the best of all worlds for mobile workers. Target industries for the device include field service workers, maintenance and service technicians in utilities and telecommunications, as well as government agencies, defence, the police and other emergency services.

- Intel® Core™ i5-1345U vPro™ processor
- Windows 11 Pro
- Next generation Dual-touch (with digitiser) display with 3:2 aspect ratio
- 12.0" QHD (2160 × 1440) anti-reflective high brightness outdoor display (up to 1200cd/m²)
- Capacitive 10 finger multi-touchscreen with glove and rain modes
- Digitiser pen embedded in the tablet
- Optional detachable keyboard with various enterprise ports and backlit* keys

- (IP65)**
- User exchangeable and hot-swappable twin batteries
- Flexible configuration port*** and business expansion module***
- Vehicle mount* available

*Optional

**Tested at Panasonic factory and does not guarantee against damage or malfunction

***One option exclusively possible in configuration port / business expansion module

- Fully rugged design with water and dust resistance

All technical specifications are subject to change without notice.



TOUGHBOOK 33 ACCESSORY ECOSYSTEM



All accessories in this guide are fully tested and certified in the Panasonic factory by Panasonic engineers

PRODUCTIVITY SOLUTIONS

Panasonic IP55 Digitiser Pen

Part No: **CF-VNP332U**



Stylus Tether

Part No: **CF-VNT002U**



Stylus Tether

Part No: **PCPE-INFUVA2**



USB External DVD Disc Drive

Part No: **PCPE-FCDVR05**



Mini USB Keyboard

With integrated touchpad.

Part No: **PCPE-KEYB**



Mini Rugged Bluetooth Keyboard

Part Nos: **PCPE-ACDS***

*UK1: UK ; FR1: French; GR1: German



Mini Antibacterial USB Keyboard

Part No: **PCPE-ACCABK***

*1: UK; 3: French; 4: German



All technical specifications are subject to change without notice.

CARRYING SOLUTIONS

Breakable Shoulder Strap

For use with most cases.
Attachment via D-rings.

Part No: **PCPE-SYSSSB1**



Shoulder Strap for TOUGHBOOK 33 Tablet

Part No: **CF-VNS331U**



User Harness

Attaches to any Toughbook 33 that provides 4-drings

Part No: **PCPE-INFUVA1**



Generic DuraStrap

For use with most cases.
Attachment via D-rings.

Size: 1651 x 25.4 x 6.35 mm /
65 x 1 x 0.25"

Weight: 136 g / 0.3 lb

Part No: **PCPE-INFGNDS**



Mobility Bundle for TOUGHBOOK 33 Tablet

Size: Corner straps: 203.2 mm / 8", Handle: 254 mm (10")

Weight: 200 g / 0.3lb

Part No: **PCPE-INF33B1**



TOUGHBOOK 33 Rotation Strap with Kick Stand

Weight: 320g / 0.7lb

Part No: **CF-VST332U**



All technical specifications are subject to change without notice.

SECURITY & PROTECTION SOLUTIONS

Kensington Lock

Part No: **PCPE-KENLOK2**



LCD Screen Cleaning Cloth

Part No: **CF-VNC002U**

MOQ: 10 pcs



Protective Film for LCD

Replacement for protective film pre-installed on TOUGHBOOK

Part No: **CF-VPF34U**



All technical specifications are subject to change without notice.

DOCKING SOLUTIONS

Desktop Port Replicator

AC adaptor not included. Use CF-AA5713A

Part No: **CF-VEB331U**

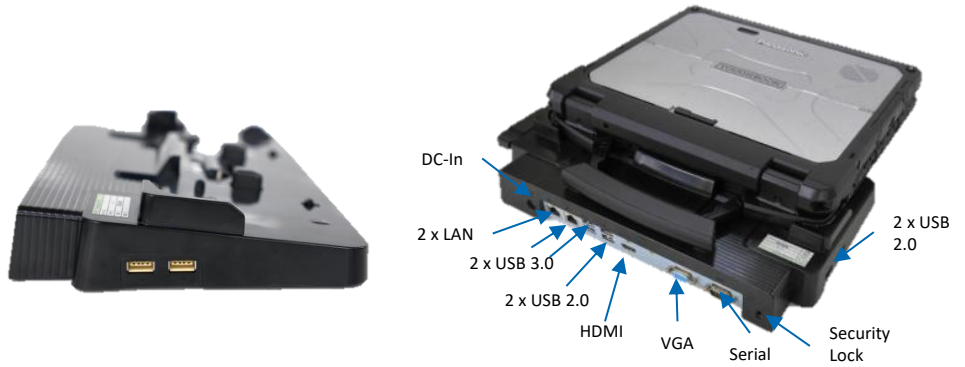

Tablet Cradle

AC adaptor not included.

Use CF-AA5713A

Part No: **CF-VEB332W**

Front



Right



Left

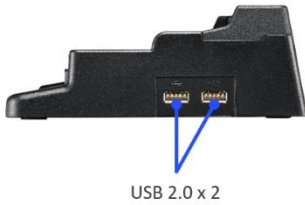

Rear

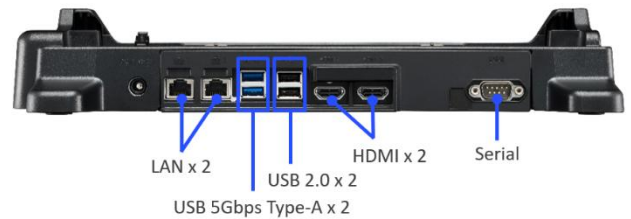

All technical specifications are subject to change without notice.

DOCKING SOLUTIONS

TOUGHBOOK 33 Laptop Vehicle Dock (GJ)

No power adaptor included. Keyed alike unless otherwise stated.

Dimensions: 358 x 343 x 89 mm / 14.1 x 13.5 x 3.5"

Weight: 3 kg / 6.7 lb

Part Nos:

- **PCPE-GJ33V06** – Full port replication, No RF
- **PCPE-GJ33V07** – Full port replication, Dual RF
- **PCPE-GJ33V08** – Non-electronic cradle

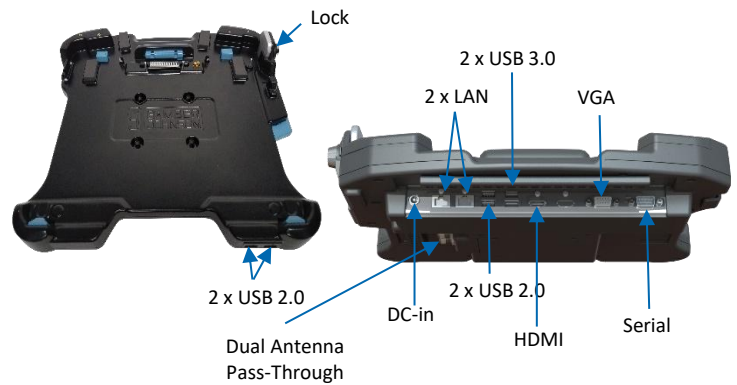

TOUGHBOOK 33 Laptop Vehicle Dock (Havis)

No power adaptor included. Keyed alike unless otherwise stated. Full port replication.

Dimensions: 300 x 327 x 88.9 mm / 11.83 x 12.88 x 3.50"

Weight: 2.44 kg / 5.38 lbs.

Part Nos:

- **PCPE-HAV3316** – Full port replication, No RF
- **PCPE-HAV3317** – Full port replication, with RF



All technical specifications are subject to change without notice.



DOCKING SOLUTIONS

Gamber Johnson TOUGHBOOK 33 Tablet Vehicle Dock

No power adaptor included. Keyed alike unless otherwise stated.

Dimensions: 317.5 x 336.5 x 114.3 mm / 12.5 x 13.25 x 4.5"

Max Weight: 1.88 kg / 4.15 lb

Part Nos:

- **PCPE-GJ33V01** - Non-electronic
- **PCPE-GJ33V02** – Full port replication, No RF
- **PCPE-GJ33V03** – Full port replication, Dual RF
- **PCPE-GJ33V04** – Lite port replication*, No RF

*No HDMI or VGA with "Lite" port replication

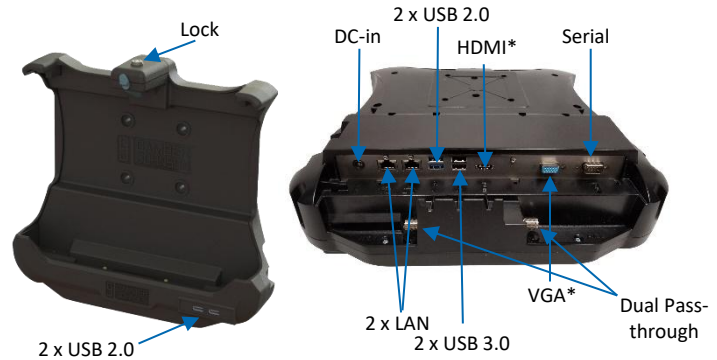

Gamber Johnson TOUGHBOOK 33 Slim Tablet Vehicle Dock

No power adaptor included. Keyed alike unless otherwise stated.

Dimensions: 314 x 274 x 76 mm / 12.3 x 10.8 x 3"

Max Weight: 2.7 kg / 6 lbs

Part Nos:

- **PCPE-GJ33V11** - Full port replication, no RF
- **PCPE-GJ33V12** - Full port replication, Dual RF

*No HDMI or VGA with "Lite" port replication

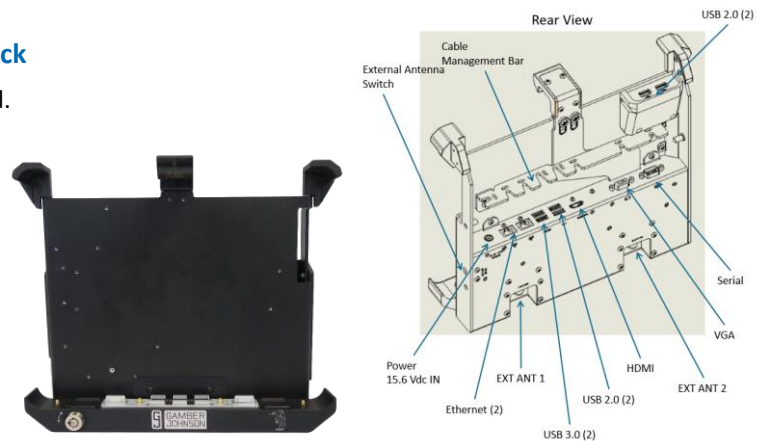

Havis TOUGHBOOK 33 Tablet Vehicle Dock

No power adaptor included. Keyed alike unless otherwise stated.

Dimensions: 300 x 327 x 88.9 mm / 11.83 x 12.88 x 3.50"

Max Weight: 1.4 kg / 3.0 lb

Part Nos:

- **PCPE-HAV3305** – Lite port replication*, no RF
- **PCPE-HAV3306** – Lite port replication*, with dual RF
- **PCPE-HAV3309** – Full port replication, no RF
- **PCPE-HAV3310** – Full port replication, with dual RF

*No HDMI or VGA with "Lite" port replication



All technical specifications are subject to change without notice.

POWER MANAGEMENT SOLUTIONS

Standard 3 Cell Battery

Part No: **CF-VZSU1AW**



Extended 6 Cell Battery

Part No: **CF-VZSU1BW**

Please note: Extended batteries are compatible only with main units configured for an extended battery.



4-bay Battery Charger

Compatible with both standard and extended battery packs.

Does not contain AC Power supply.

Part No: **CF-VCB331W**



AC Power Supply

For use with device and desk dock.

Part No: **CF-AA5713A2***

*E: UK; G: EU; T: Italy; D: Switzerland



Charger For Forklifts

Part Nos:

- **PCPE-LNDFH11:** 70-110V
- **PCPE-LNDFH32:** 12-32V
- **PCPE-LNDFH60:** 20-60VDC



Car Charger

120 W, 12-32Vdc input

Part No: **CF-LND1224A**



Car Charger

90W, 12-16VDC input

Part Nos:

- **CF-LND80S-FD** – cigarette plug
- **CF-LND80SBW** – Bare wire



Car Charger

90 W, 12-32VDC input

Part Nos:

- **CF-LND8024FD** - cigarette plug
- **CF-LND8024BW** - bare wire



Mil Spec Car Charger

120W, 22-32 VDC

Part No:

- **PCPE-LND3676**



Car Charger

120 W, 12-16VDC input

Part No:

- **TB-HAV-PSU2** - bare wire



All technical specifications are subject to change without notice.

PROFESSIONAL SERVICES

Custom BIOS Services

Part No: **PCPE-PSBIOSG**

Autopilot Enrolment

Part No: **PCPE-PSAUTOP**

SIM Installation

Part No: **PCPE-PSSIMIN**

Information Management Bundle

IMEI, MAC, SIM, ASSET, Hardware Hash reporting.

Part No: **PCPE-PSATAGB**

Solution Packaging

Up to 10 items packaged together in a box.

Does not include custom designed case.

Part No: **PCPE-PSSPACK**

Custom Imaging

Part Nos:

- **PCPE-PS20GIM - Image deployment per device (MOQ 30)**
- **Custom Image Creation - Price on request.**

Customer Branding

Logo badge on device casing or bezel.

Part No: **PCPE-PSLOGOB**

Asset Tagging

Standard, using CPE label set.

Part No: **PCPE-PSATAG1**

Custom Logistics

Part No: **PCPE-PSCDL01**

Price on Request.

All technical specifications are subject to change without notice.

PROTECT FULL MAINTENANCE SERVICES



ProTect PLUS

Every TOUGHBOOK is supported by our standard three year ProTect service, but ProTect PLUS is a value-packed upgrade, offering you extra peace of mind through the additional of the following services:

- Battery Confidence: proactive battery replacement (3 years only)
- Monthly service reporting on full estate of devices
- One working day of on-demand consultancy every year
- Full access to the TOUGHBOOK ServiceCloud Advanced Knowledge Base
- Remote technical support
- Full inspection report for returned devices
- Small, cosmetic repairs and reinstatement of IP integrity

SKU	Description
PCPE-PROTP3	TOUGHBOOK ProTect PLUS 3 Years (Incl. 3 yr Battery Confidence)
PCPE-PROTP4	TOUGHBOOK ProTect PLUS 4 Years (Incl. 3 yr Battery Confidence)
PCPE-PROTP5	TOUGHBOOK ProTect PLUS 5 Years (Incl. 3 yr Battery Confidence)



ProTect PLUS Premium

For the ultimate protection, tailor your service plan by adding on any of the ProTect PLUS Premium modules below:

- Infinity Maintenance Service – *Infinity pricing all ProTect PLUS services. Other Premium modules below are priced on top of Infinity.*
- Remote Device Monitoring
- Self-Maintenance: Training & Spare Parts Access
- Return without SSD
- Global Service
- Device Management
- Software Maintenance
- Rapid Replacement
- Alternative Packaging

SKU	Description
PCPE-INFAB3	TOUGHBOOK Infinity 3 Years (Incl. 3 yr Battery Confidence)
PCPE-INFAB4	TOUGHBOOK Infinity 4 Years (Incl. 3 yr Battery Confidence)
PCPE-INFAB5	TOUGHBOOK Infinity 5 Years (Incl. 3 yr Battery Confidence)

ENTERPRISE MOBILITY INTELLIGENCE



TOUGHBOOK Smart Essentials Suite

Real time analytics, powered by B2M Solutions, showing the health and performance of your estate of mobile devices, focussing on areas such as battery life, data usage, disruptions and connectivity. Enables the user to recognise patterns of usage and potentially pre-empt issues before they arise. The full suite includes access to the core dashboard as well as the Smart Battery Monitor dashboard, and APIs.

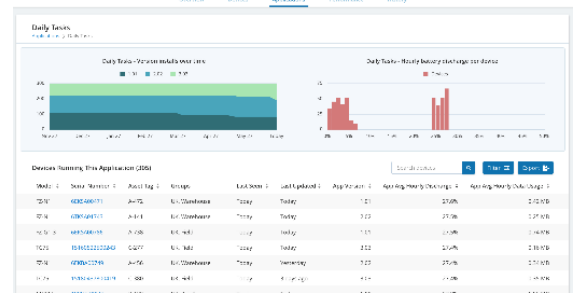

SKU	Description
CF-LESPSESS1	Smart Essentials Bundle - 1 year (Smart Service, Battery Monitor and APIs)
CF-LESPSESS3	Smart Essentials Bundle - 3 year (Smart Service, Battery Monitor and APIs)
CF-LESPSESS5	Smart Essentials Bundle - 5 year (Smart Service, Battery Monitor and APIs)

Smart Battery Monitor

Smart Battery Monitor gives users real time insight into battery usage and health in detail cross an estate of devices. It focuses on battery serial numbers and allows the user to track, identify and replace batteries before they impact productivity. Alerts can also be set up.

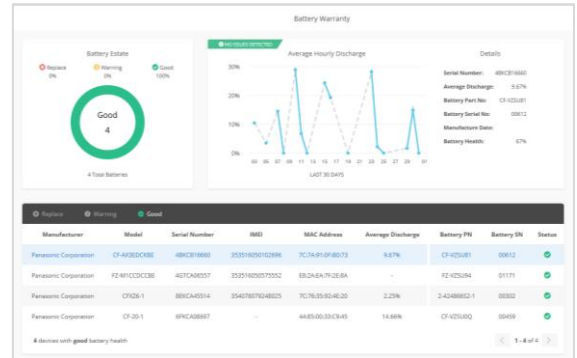

SKU	Description
CF-LESPBAEE1	1 Year Smart Battery Monitor (Elemex Battery Essentials)
CF-LESPBAEE3	3 Year Smart Battery Monitor (Elemex Battery Essentials)
CF-LESPBAEE5	5 Year Smart Battery Monitor (Elemex Battery Essentials)

SOFTWARE SOLUTION PARTNERS

ABSOLUTE[®]

Cyber Resilience

Absolute is the industry benchmark in endpoint resilience. It ensures customers' digital operations and mobile workforces stay efficient, productive, and safe using innovative [Secure Endpoint](#) and [Secure Access](#) products—leveraging the advantage of pioneering Absolute Persistence[®] technology embedded in the firmware of more than 600,000,000 devices. Once activated, Absolute Persistence is fiercely and uniquely resilient, surviving attempts to disable it, even if the device is re-imaged, the hard drive is replaced, or the firmware is updated. **No other technology can do this.**

Contact your sales rep for part numbers.

Website: <https://www.absolute.com/partners/device-compatibility/#panasonic>

SOTI[®]

Enterprise Mobility Management

Part of the [SOTI ONE Platform](#), SOTI MobiControl is the Enterprise Mobility Management (EMM) solution designed for any device, any form factor, and any operating system (OS). Deploy apps to smartphones. Enroll and provision new tablets in the field. Track the location of rugged devices. Identify and neutralize security risks to the IoT endpoints. Protect critical data stored on mobile devices. Minimize device downtime so field workers stay productive.

Contact your sales rep for part numbers.

Website: <https://www.soti.net/products/soti-mobicontrol/>



Sygic

Sygic Professional GPS Navigation works offline and features truck specific routing, itinerary with time windows and over 60 APIs for development with Android and Windows based apps. Sygic technology is accessible through a complete set of SDKs for web and mobile development. During Sygic's 18-year experience, we developed countless mapping and navigation solutions for 3000+ integration partners and customers in various industries.

Contact your sales rep for part numbers.

Website: <https://www.sygic.com/enterprise/professional-gps-navigation-sdk>



ACCESSORY SUMMARY 1

Solution Type	Part Number	Description
Power Management	CF-VZSU1AW	Standard 3 Cell Battery
	CF-VZSU1BW	Extended 6 Cell Battery
	CF-VCB331W	4-Bay Battery Charger
	CF-AA5713A2E/G/T/D	AC Power Supply
	CF-LND1224A	Car Charger (120W, 12-32 VDC)
	CF-LND80S-FD/BW	Car Charger (90W, 12-16 VDC)
	CF-LND8024FD/BW	Car Charger (90W, 12-32 VDC)
	PCPE-LNDFH11	Car Charger (70-110V) For forklift
	PCPE-LNDFH32	Car Charger (12-32V) For forklift
	PCPE-LNDFH60	Car Charger (20-60VDC) For forklift
	PCPE-LND3676	Mil Spec Car Charger (120W, 22-32 VDC)
TB-HAV-PSU2	Car Charger (120W, 12-16VDC)	
Docking Solutions	CF-VEB331U	TOUGHBOOK 33 Desktop Port Replicator
	CF-VEB332W	TOUGHBOOK 33 Tablet Cradle
	PCPE-GJ33V 06/07/08	Gamber Johnson TOUGHBOOK 33 Laptop Vehicle Dock
	PCPE-GJ33V 01/02/03/04	Gamber Johnson TOUGHBOOK 33 Tablet Vehicle Dock
	PCPE-GJ33V 11/12	Gamber Johnson TOUGHBOOK 33 Slim Tablet Vehicle Dock
	PCPE-HAV33 16/17	Havis TOUGHBOOK 33 Laptop Vehicle Dock
	PCPE-HAV33 05/06/07/10	Havis TOUGHBOOK 33 Tablet Vehicle Dock
Styluses	CF-VNP332U	Panasonic IP55 Digitiser Pen
	CF-VNT002U	Stylus Tether
Keyboards	PCPE-KEYB	Mini USB Keyboard
	PCPE-ACDSUK1/FR1	Mini Rugged Bluetooth Keyboard
	PCPE-ACCABK1/2/3/4	Mini Antibacterial USB Keyboard
Carrying Solutions	PCPE-SYSSSB1	Breakable Shoulder Strap
	CF-VNS331U	Shoulder Strap for TOUGHBOOK 33 Tablet
	PCPE-INF33B1	Mobility Bundle for TOUGHBOOK 33 Tablet
	PCPE-INFUVA1	User Harness
	PCPE-INFGNDS	Generic Dura Strap
	PCPE-INFBPK1	General Backpack
	CF-VST332U	TOUGHBOOK 33 Rotation Strap with Kick Stand

All technical specifications are subject to change without notice.

ACCESSORY SUMMARY 2

Solution Type	Part Number	Description
Protection & Security	CF-VNC002U	Cleaning Cloth for LCD
	CF-VPF34U	LCD Protective Film
	PCPE-KENLOK2	Kensington Lock
Optical Drive	PCPE-FCDVR05	Slimline External CD/DVD Writer
Professional Services	PCPE-PSBIOSG	Custom BIOS Service – Gold
	PCPE-PS20GIM	Image deployment per device (MOQ 30)
	PCPE-PSSIMIN	SIM Installation
	PCPE-PSATAG1	Asset Tagging
	PCPE-PSATAGB	Information Management Bundle
	PCPE-PSAUTOP	Autopilot Enrolment
	PCPE-PSLOGOB	Custom logo badge
	PCPE-PSSPACK	Solution Packaging
	PCPE-PSCDL01	Customised Deployment / Logistics
	PCPE-PSBTM01	Bespoke Training Material
Protect Full Maintenance Services	PCPE-PROTP3	TOUGHBOOK ProTect PLUS 3 Years (Incl. 3 yr Battery Confidence)
	PCPE-PROTP4	TOUGHBOOK ProTect PLUS 4 Years (Incl. 3 yr Battery Confidence)
	PCPE-PROTP5	TOUGHBOOK ProTect PLUS 5 Years (Incl. 3 yr Battery Confidence)
	PCPE-INFAB3	TOUGHBOOK Infinity 3 Years (Incl. 3 yr Battery Confidence)
	PCPE-INFAB4	TOUGHBOOK Infinity 4 Years (Incl. 3 yr Battery Confidence)
	PCPE-INFAB5	TOUGHBOOK Infinity 5 Years (Incl. 3 yr Battery Confidence)
Smart Essential Suite	CF-LESPSESS1	Smart Essentials Bundle - 1 year (Smart Service, Battery Monitor and APIs)
	CF-LESPSESS3	Smart Essentials Bundle - 3 year (Smart Service, Battery Monitor and APIs)
	CF-LESPSESS5	Smart Essentials Bundle - 5 year (Smart Service, Battery Monitor and APIs)
Smart Battery Monitor	CF-LESPBAEE1	1 Year Smart Battery Monitor (Elemex Battery Essentials)
	CF-LESPBAEE3	3 Year Smart Battery Monitor (Elemex Battery Essentials)
	CF-LESPBAEE5	5 Year Smart Battery Monitor (Elemex Battery Essentials)

All technical specifications are subject to change without notice.